

MICHIGAN DEPARTMENT OF TRANSPORTATION

ROUTE: M-66
 CITY OF LAKE CITY
 FOREST TOWNSHIP
 MISSAUKEE COUNTY

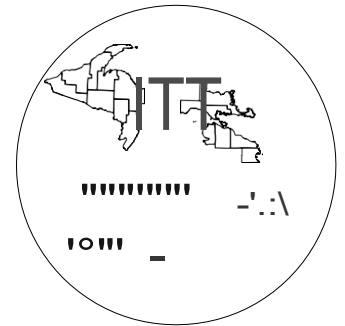

COUNTY KEY

SECTION _____ CONTROL SEC 57013 JOB NO. MAINTANENCE FED AID PROJ NO

TRAFFIC DATA				SPEED DATA			LIMITS
ROAD	YEAR	ADT	COMM	DESIGN	POSTED		
M-55	2023	7745	1270	35	35	INTERSECTION M55 & M66	
M-66	2023	10,833	1223	35	35	INTERSECTION M55 & M66	

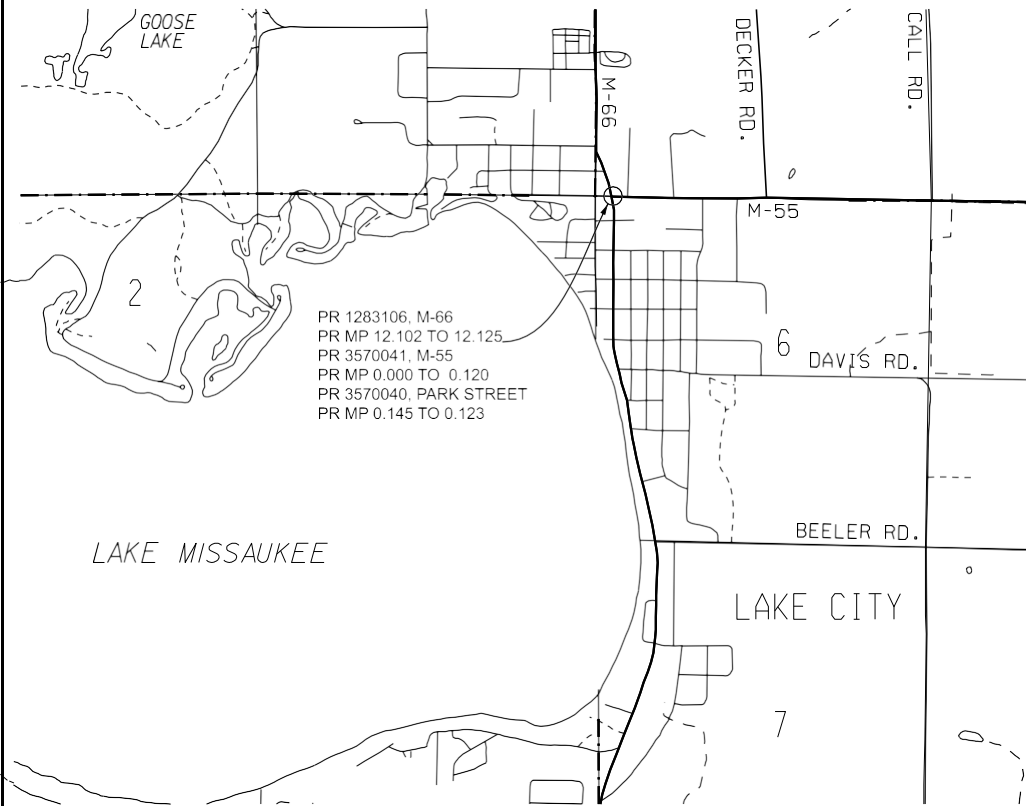

THE IMPROVEMENTS COVERED BY THESE PLANS SHALL BE DONE IN ACCORDANCE WITH THE MICHIGAN DEPARTMENT OF TRANSPORTATION 2020 STANDARD SPECIFICATIONS FOR CONSTRUCTION. PHYSICAL ROAD NUMBER (PR#) & MILEPOST (MP) DATA ARE FROM MICHIGAN GEOGRAPHIC FRAMEWORK VERSION# 24.

MILES: 0.009
 CONTRACT FOR:
 EXPLORATORY EXCAVATION AND
 STABILIZATION OF ROAD BASE,
 INCLUDING COLD MILLING, AND HMA
 PAVING OF ADJACENT PAVEMENT

BRADLEY C. WIEFERICH, P.E. - DIRECTOR

1stMDOT
 Michigan Department of Transportation

NO SCALE

DESIGN UNIT: PORATH
 CS: 57013
 JN: MAINTANENCE

TSC: TRAVERSE CITY

TITLE SHEET

DATE: 2024-12-10

DRAWING SHEET

TITLE
 M-66
 001

SECT 1

FILE: M66 TITLE SHEET.DGN

LOG OF PROJECT

PROJECT LOCATION

The northern intersection of M-66 and M-55 in the City of Lake City, Missaukee County. Construction limits within the intersection are identified by the following three segments: segment one PR 1283106, PR MP 12.102 to 12.125 on M-66; segment two PR 3570041 from PR MP 0.000 to 0.120 on M-55; segment three PR 3570040 from PR MP 0.145 to 0.153 on Park Street.

PROJECT DESCRIPTION

This project includes full depth removal of a section of pavement and underlying aggregate base and subbase, repairs to the subgrade, geotextile stabilization, and repaving along with the associated work to maintain traffic via detour and traffic regulator control. Additionally, the surrounding intersection pavement will be milled and resurfaced.

ITEMS OF WORK

EXCAVATION AND RESTORATION

M-55 & M-66 Pavement Repair: Areas designated on plans, remove existing HMA, aggregate base, and subbase material to perform exploratory excavation. Place flowable fill as needed on areas of subgrade instability where unstable materials are not completely removed by excavation. Perform exploratory excavation in the location of removal. Limits of pavement repair to be reconstructed with geotextile stabilization layer below 6 inches of 21AA. Construct project in accordance with the MDOT 2020 Standard Specifications for Construction and accompanied special provisions for this project. Estimated project quantities are listed below:

Flowable Fill, Non-Structural	20	Cyd
HMA Surface, Rem	167	Syd
Exploratory Investigation, Vertical	100	Ft
Excavation, Earth	28	Cyd
HMA, 5EMH	170	Ton
Edge Trimming	160	Ft
Aggregate Base, 6 inch	167	Syd
Geotextile, Stabilization	167	Syd
Subbase, CIP	20	Cyd
Cold Milling, HMA	967	Syd

MAINTAINING TRAFFIC ITEMS

Maintain traffic in accordance with the 2020 Standard Specifications for Construction, including any supplemental specifications, and as herein specified. All traffic control devices and their usage shall comply with the 2011 edition of the Michigan Manual of Uniform Traffic Control Devices (MMUTCD).

The maintenance of traffic will be according to the plans in this document. Project quantities are listed below:

Barricade, Type III, High Intensity, Double Sided, Lighted, Oper	24	Ea
Barricade, Type III, High Intensity, Double Sided, Lighted, Furn	24	Ea
Sign Type B, Temp, Prismatic, Furn	541	Sft
Sign Type B, Temp, Prismatic, Oper	541	Sft
TS Face, Bag	12	Ea
TS Face, Bag, Rem	12	Ea
Plastic Drum, Fluorescent, Furn	25	Ft
Plastic Drum, Fluorescent, Oper	25	Ea
Sign, Type B, Temp, Prismatic, Oper	509	Sft
Sign, Type B, Temp, Prismatic, Furn	509	Sft
Sign, Portable, Changeable Message, NTCIP-Complaint, Furn	5	Ea
Sign, Portable, Changeable Message, NTCIP-Complaint, Oper	5	Ea

Sign, Type B, Temp: Quantity breakdown for Sign, Type B, Temp, Prismatic, Furn item:

SIGN	SIZE (Sft)	QTY	TOTAL (Sft)
M3-1	2	13	26
M3-3	2	16	32
M6-1L	3	10	30
M6-3B	3	6	18
M6-1R	3	8	24
M4-8	2	27	54
M1-6	3	28	84
M4-8A	3	15	15
M4-4	2	21	42
TYPE III BARRICADE	N/A	24	24
R11-2	10	4	40
W20-1	16	4	64
W20-2	16	4	64
R11-3A	4	4	16

ENTIRE PROJECT QUANTITIES

The following quantities are estimated for use where needed throughout the project as directed by the Engineer.

Mobilization, Max	1	LSUM
Minor Traffic Devices	1	LSUM
Traffic Regulator Control	1	LSUM

GENERAL NOTES

Work is scheduled between existing pavement markings. There are no scheduled removal or replacement of existing pavement markings. Contractor to preserve existing pavement markings.

Detour and changes to traffic patterns to be coordinated with MDOT Traverse City Traffic and safety Engineer and MCRC Engineer prior to any changes outside of the scheduled detour.

Schedule any changes to overhead traffic signalization during closure within the intersection with MDOT Traverse City Traffic and Safety Engineer.

Jessica Carpenter PE
Michigan Department of Transportation
Traverse City TSC
2084 US-31, Traverse City MI, 49685
231-941-1986

MATERIAL TESTING

Bituminous materials used on this project will be verified to match mix design supplied by MDOT through means of extraction and subject to Michigan Department of Transportation testing tolerances prior to acceptance of project completion. A sample of the placed bituminous mixture, as specified in the plans, will be retained by MDOT.

Density testing will be required on any aggregate bases paid for within this contract per MDOT Standard Specifications for Construction 2020 sections 302 and 307. The testing and inspection will be completed by MDOT.

UTILITIES

MISS DIG/UNDERGROUND UTILITY NOTIFICATION

Contact MISS DIG System, Inc. for the protection of underground utilities and in conformance with MCL 460.721 et seq, via the web at <https://www.missdig811.org> or by phone at 811 or 800-482-7171 a minimum of 3 working days prior to excavating, excluding weekends and holidays.

STANDARD PLANS

There are no standard plans associated with items of work within this contract. RFI can be sent to MDOT Traverse City TSC in the event additional coordination of contract items is required.

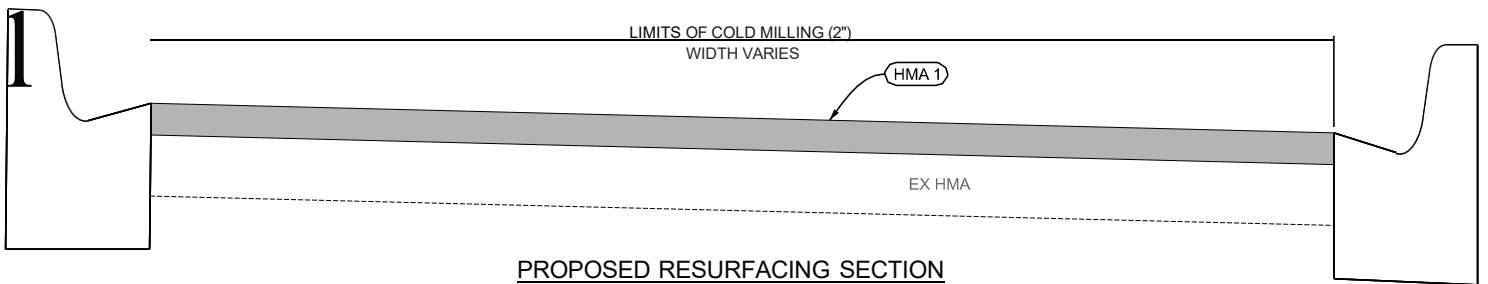
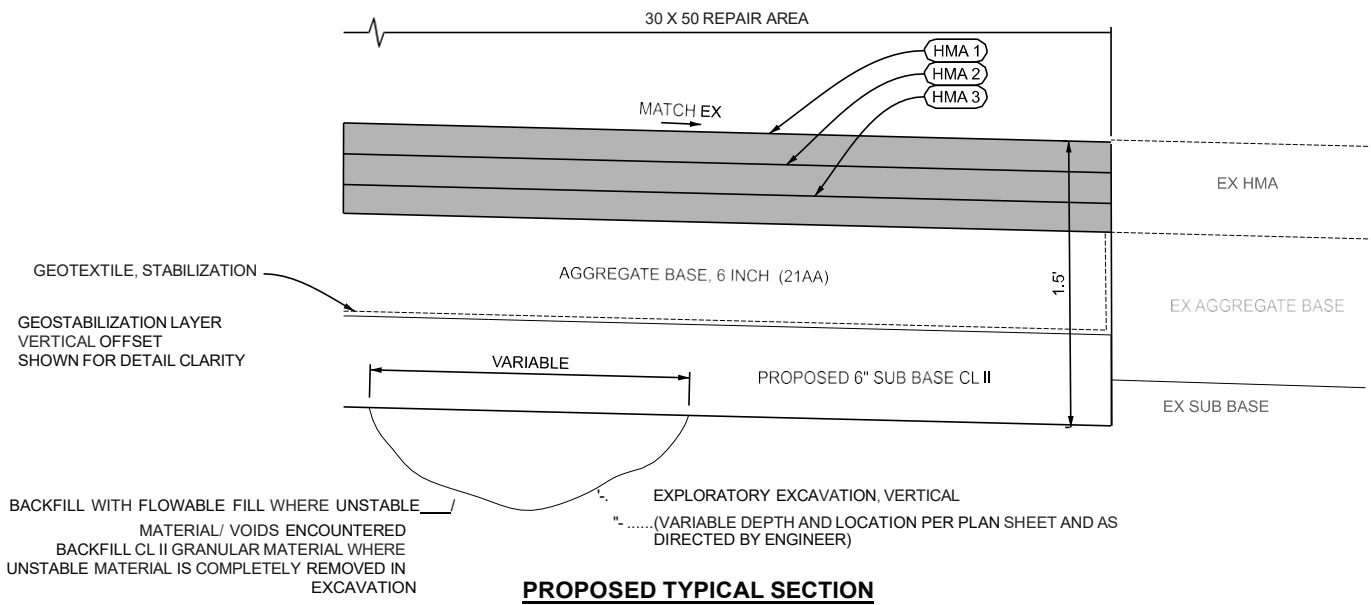
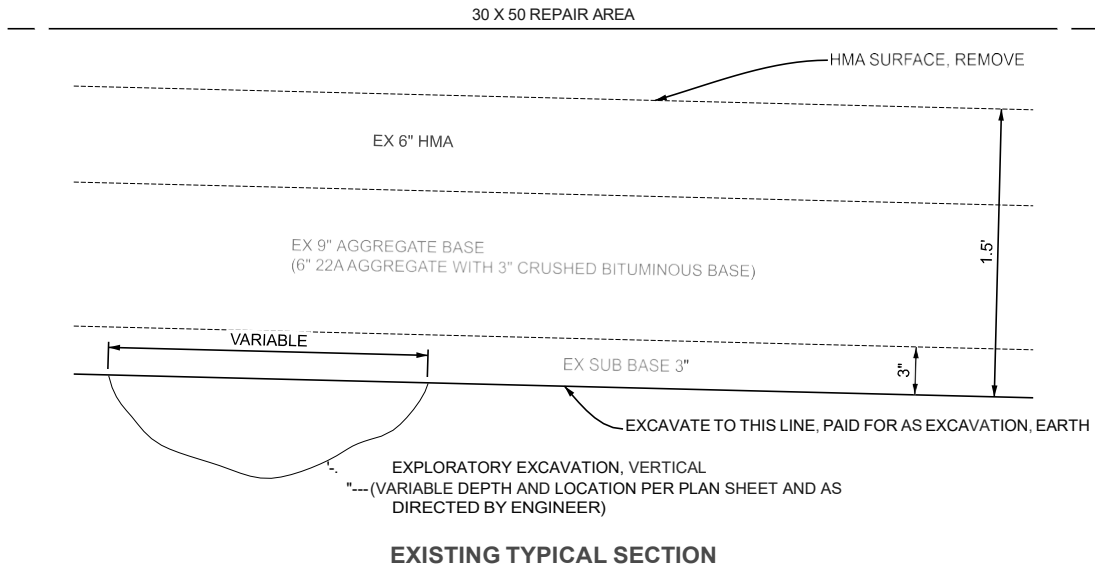

tt.MDOT Michigan Department of Transportation	NO SCALE	DESIGN UNIT: PORATH	TSC: TRAVERSE CITY TSC	DATE: 2025-03-12	
		CS: 57013	TYPICAL CROSS SECTIONS		DRAWING SHEET
		JN: MAINTENANCE		M66 TYP 001	SECT 1
FILE: M66TYPICAL.DGN					



M-66

**ESTIMATED QUANTITIES THIS SHEET
FOR INFORMATIONAL PURPOSES ONLY**

FLOWABLE FILL, NON-STRUCTURAL	CYD	20
HMA SURFACE, REM	CYD	167
EXPLORATORY INVESTIGATION, VERTICAL	FOOT	100
EXCAVATION, EARTH	CYD	70
HMA, 5EMH	TON	60
EDGE TRIMMING	FOOT	160
AGGREGATE BASE, 6 INCH	TON	55
GEOTEXTILE, STABILIZATION	SYD	167
SUBBASE, CIP	CYD	28

APPROXIMATE LOCATIONS OF EXPLORATORY EXCAVATION
REQUIRED IN AREAS OF FAILURE

(1) AGGREGATE 21A SHALL BE PLACED AT 6" DEPTH
OVER TOP OF GEOTEXTILE STABILIZATION

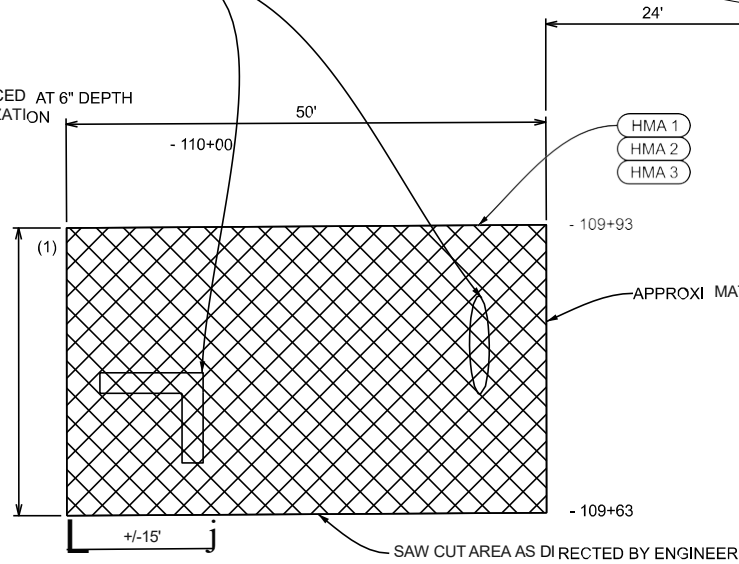

HMA APPLICATION ESTIMATE

IDENT NO.	ITEM	RATE LBS PER SYD	PERFORMANCE GRADE	REMARKS
HMA1	5EMH	220	64-28	TOP COURSE AWI =260
HMA2	5EMH	220	64-28	
HMA3	5EMH	220	64-28	
	SOND COAT	0.05-0.15 GAL		

t.MDOT
Michigan Department of Transportation

FILE: M-66 INTERSECTION.DGN

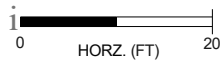

DATE: 2024-12-05

DESIGN UNIT: PORATH

TSC: TRAVERSE CITY

CS: 57013

JN: MAINTENANCE

M-66 INTERSECTION DETAIL
RECONSTRUCTION LIMITS

DRAWING SHEET

M-66
DET
001

SECT 1



M-66

ESTIMATED QUANTITIES THIS SHEET
FOR INFORMATIONAL PURPOSES ONLY

HMA, 5EMH
COLD MILLING, HMA

TON 110
SYD 967

COLD MILLING, HMA(2")

HMA 1

- 110+00

- 109+93

M-55

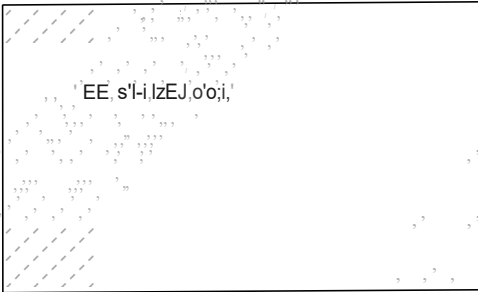

-109+63

-109+43

MAINTAIN MILLING LIMITS INSIDE OF EXISTING PAVEMENT MARKINGS
REMOVAL AND RESURFACING ITEMS WITHIN LIMITS
OF REPAIR AREA PAID FOR UNDER RECONSTRUCTION ITEMS
SHEET001

t.MDOT
Michigan Department of Transportation

FILE: M-66 INTERSECTION.DGN

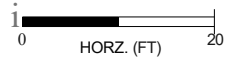

DATE: 2024-12-05

DESIGN UNIT: PORATH

TSC: TRAVERSE CITY

CS: 57013

JN: MAINTENANCE

M-66 INTERSECTION DETAIL

RESURFACING LIMITS

DRAWING SHEET

M-66 DET 002 SECT 1

G) INDRTHi M3-1
24" X 12" QTY EA 13

Q) isourml M3-3
24" X 12" QTY EA 16

Ⓡ IE 21" X 15"
M6-1 (L) QTY EA 10

Ⓡ [I] 21" X 15"
M6-3b QTY EA 6

(j) 8 M6-1 (R)
21" X 15" QTY EA 8

@ idHOURi M4-8
24" X 12" QTY EA 27

Ⓡ M1-6
18" X 18" QTY EA 28

PCMS BOARD QTY 5 EA

G " M4-8a
24" X 18" QTY EA 5

@ riiiiiiii M4-4 (24" X 12")
2 SFT SIGN, TYPE IIIB QTYEA21

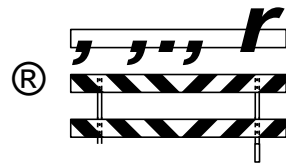

TYPE 111 BARRICADE FOR CLOSURE

QTY EA 24

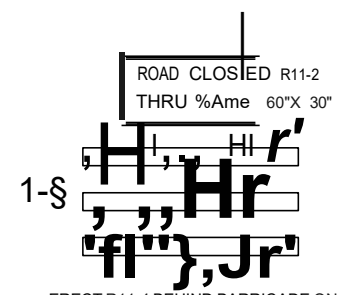

ERECT R11-4 BEHIND BARRICADE ON SEPARATE SIGN SUPPORTS. PLACE TYPE III BARRICADE AND R11-4 ON THE SHOULDER.

QTYEA4

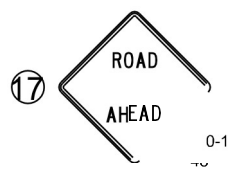

QTY EA 4

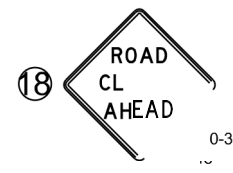

QTY EA 4



QTYEA 4

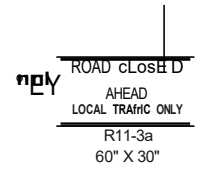

QTYEA 4

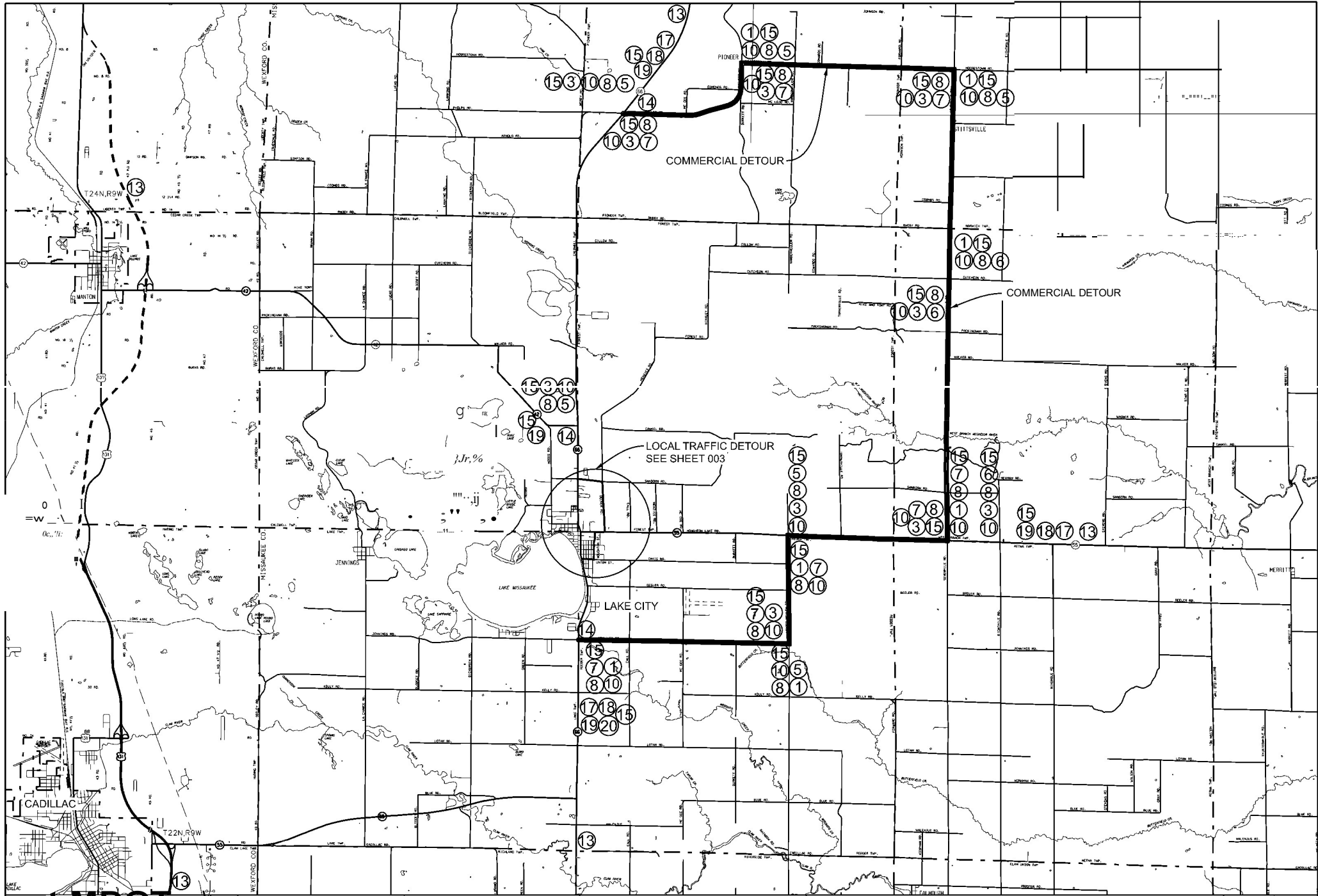

t.MDOT
Michigan Department of Transportation

NO SCALE

DATE: 02-21-2025
DESIGN UNIT: PORATH
TSC: TRAVERSE CITY TSC

CS: 57013
JN: MAINTANENCE

M-55 AT M-66 INTERSECTION DETOUR MAP
COMMERCIAL DETOUR

DRAWING SHEET
M55 M66 SECT 1
DET
002

LAKE CITY



GREEN

17 18 19 20

3 5 8 10 14

1 5 8 10

3 7 8 10

0
77
n
A
77
:::0
:::0
0

n
D
i
i
:::0
0

1 7 8 10

3 6 8 10

FOREST TWP.

20
9 12 EA
20 16 4 EA

3 5 8 10

3 7 8 10

1 7 8 10

LAKE MISSAUKEE

17 18 20
19 20 1 7 8 10 1 5 8 10

14 3 7 8 10

HOUGHTON ST.

UNION ST.

MDOT
Michigan Department of Transportation

NO SCALE

DATE: 02-21-2025
DESIGN UNIT: PORATH
TSC: TRAVERSE CITY TSC

CS: 57013
JN: MAINTANENCE

M-55 AT M-66 INTERSECTION DETOUR MAP
LOCAL DETOUR

DRAWING SHEET
M55 M66 SECT 1
DET 003

FILE: M55 DETOUR.DGN

MICHIGAN
DEPARTMENT OF TRANSPORTATION

SPECIAL PROVISION
FOR
MAINTAINING TRAFFIC

TRV:JLC

1 of 5

APPR:TRV:JPJ:02/14/2025

a. Description. This special provision consists of requirements and restrictions to maintain traffic on M-55 and M-66 in the city of Lake City, Missaukee County.

b. General. Maintain traffic throughout the project in accordance with the standard specifications, typicals, and supplemental specifications in the contract and as described on the plans for this project.

c. Construction Influence Area (CIA). The CIA includes the right-of-way of the following roadways, within the approximate limits described below:

1. On M-66 from approximately 1 mile north to 1 mile south of the intersection with M-55.
2. On M-55 from approximately 1 mile east to 1 mile west of the intersection with M-66.

3. In addition, the CIA includes the right-of-way of any designated detour route or alternate route, intersecting roads and ramps adjacent to the work zone for a distance of approximately 1/4 mile in advance of the work zone or as far as the construction or detour signing extends.

d. Traffic Restrictions. Maintain traffic in accordance with the Maintaining Traffic Typicals contained herein, except as noted below. Changes or adjustments to the Maintaining Traffic Typicals may be necessary to fit field conditions, subject to approval of the Engineer or as determined by the Engineer.

1. Utilize the following Maintaining Traffic Typicals:
 - A. 100-GEN-KEY
 - B. 101-GEN-SPACING-CHARTS
 - C. 102-GEN-NOTES
 - D. 103-GEN-SIGN
 - E. 104-GEN-AB
 - F. WZD-100-A
 - G. WZD-125-E

2. Do not work, deliver material, or close lanes on Sundays, Saturdays, or during the holiday periods as defined in Table 1 unless approved by the Engineer.

Table 1: 2025 Holiday Periods

Holiday	Start Date and Time	End Date and Time
Memorial Day	3:00 pm, Friday, 05/23/25	6:00 am, Tuesday, 05/27/25
Independence Day	3:00 pm, Thursday, 07/03/25	6:00 am, Monday, 07/07/25
Labor Day	3:00 pm, Friday, 08/29/25	6:00 am, Tuesday, 09/02/25

3. Do not deliver material, or close lanes during the Special Events as defined in Table 2.

Table 2: 2025 Special Events

Local Event	Start Dates and Time	End Date and Time
Car Cruise and Car Show	3:00 p.m. Thursday, 08/07/25	6:00 a.m. Monday, 08/11/25
Festival of the Pines	3:00 p.m. Thursday, 09/18/25	6:00 a.m. Monday, 09/22/25

4. Perform work between sunrise and sunset, local time, unless otherwise approved by the Engineer.

5. Close the intersection of M-55 at M-66 to traffic to complete work.

6. Maintain commercial traffic using the designated commercial detour routes per the plans.

7. Maintain non-commercial traffic using the designated local detour route per the plans.

8. Maintain access to all driveways as directed by the Engineer unless prior agreements are made with the respective property owners.

e. Traffic General.

1. Prior to opening any lanes and/or shoulders, remove, by sweeping all accumulated debris that has collected within the closed lane/shoulder.

2. A speed reduction will not be used.

3. Develop and submit to the Engineer an Internal Traffic Control Plan (ITCP) per subsection 104.11.B of the Standard Specifications for Construction. The requirements listed herein are the requirements for a Type A ITCP. Submit the Type A ITCP at the preconstruction meeting. The Engineer will have 7 calendar days to review the ITCP for approval or provide comments for revisions required to obtain approval. Include in the ITCP, at a minimum, the proposed ingress/egress locations for construction equipment and vehicles, traffic control devices that will be utilized to warn the motoring public of ingress/egress locations, and measures that will be taken to ensure compliance with the ITCP. Ensure that the ITCP minimizes conflicts between construction vehicles and motorists and maintains overall safety and mobility within the work zone. No work may begin prior to approval of the ITCP. Additional

time required to obtain an approved ITCP will not be cause for delay or impact claims. All costs associated with obtaining an approved ITCP, providing and executing all parts of the approved ITCP including required traffic control devices, or resolving an incomplete or unacceptable ITCP will be borne by the Contractor.

4. Protect the work area at the end of each day. Close all open access points on the project to traffic with Type III barricades or other devices approved by the Engineer.

5. The Engineer will be responsible for notifying emergency services, transit agencies, law enforcement and schools prior to any lane closures, detours or major traffic shifts. In addition, the Contractor will be responsible for working with and complying with any coordination that is necessary with the Department and emergency services, transit agencies, law enforcement and schools. All costs associated with these coordination efforts will be considered included in the pay item "Minor Traf Devices".

5. Obtain all necessary permits from local governments within areas of local jurisdiction, including noise/dust ordinance waivers when required, prior to placing construction signing on local roads.

A. The Department will reimburse permit costs in accordance with subsection 107.02.A of the Standard Specification for Construction. Adhere to all requirements made by local maintaining agencies regarding placement of traffic control devices prior to closing lanes on roadways not under MDOT jurisdiction.

6. Remove all temporary traffic control devices from MDOT right-of-way during any shut down periods unless needed for directly maintaining or channelizing traffic. No additional payment will be made for removal and/or redeployment of these devices except for in the case of an approved extension of time.

7. Once work is initiated that includes any lane restrictions, that work must be continued daily until completed. A lack of work activity for more than 3 days will require the removal of lane closures at no expense to the Department.

f. Detours.

1. Do not detour traffic until all proposed contract work on the detour route is completed, inspected, and approved by the Engineer.

3. Cover all detour signs installed prior to closing a road. Do not uncover detour signing until just before the closure is in effect. Immediately remove or cover all detour signing upon opening the road to traffic.

g. Pedestrian or Non-Motorized Facilities.

1. Maintain all facilities in accordance with *The Americans with Disability Act (ADA)* requirements and the *Public Rights-of Way Accessibility Guidelines (PROWAG)*. Provide facilities equivalent to or better than the route a person would have encountered prior to construction activities.

2. Always keep sidewalk areas clear of any equipment or materials when the sidewalks are open to pedestrian traffic. When open to pedestrian traffic, maintain a 4 foot clear path on all sidewalks.

h. Earthwork and Excavation.

1. Use protective fencing to protect open excavations within the work zone during non-working hours.

i. Traffic Control Devices. Ensure all traffic control devices are in accordance with the *MMUTCD* and must meet the “acceptable” criteria as defined in the *ATSSA* publication entitled “*Quality Guidelines for Temporary Traffic Control Devices and Features*” at the time of initial deployment and after each major stage change.

1. During non-working periods, place applicable advance signs and channelizing devices at specific locations, as directed by the Engineer, at no additional cost to the Department.

2. Notify the Engineer 24 hours in advance of when traffic control devices are being delivered to the project site, to allow for initial inspection of devices to take place.

3. Remove from the project site all traffic control devices (including detour signing) no longer needed for a particular operation and equipment for construction within 5 work days of reopening the shoulder/lane/roadway.

4. Channelizing Devices.

A. Ensure all devices have sufficient ballast to prevent moving or tipping. If moving or tipping occurs, place additional ballast, as directed by the Engineer, at no additional cost to the Department. No more than two ballasts are allowed on each channelizing device.

B. Do not use caution tape on channelizing devices for traffic control and/or pedestrian traffic control on this project.

5. Temporary Signs.

A. Additional W20-1 (ROAD WORK AHEAD) signs are included in the quantities to be placed on all intersecting or adjacent roads where construction activities may be encountered.

6. Portable Changeable Message Signs (PCMS's). Use PCMS's to warn traffic of upcoming and changing traffic control during the life of the project. Obtain approval from the Engineer for all sign locations.

A. Install PCMS's and make them operational a minimum of 7 calendar days prior to the start of work, unless otherwise directed by the Engineer. Messages displayed on the PCMS's must conform to MDOT's policy on PCMS's. Notify the Engineer if displaying a different message than those listed below for the project.

B. Do not leave PCMS's with a blank screen within the clear zone of any roadway at any time. Remove the PCMS or display flashing dots in each corner of the screen when

there is no message to display. Update the PCMS messages at the end of each work period to reflect current traffic lane restrictions.

C. Display the following two messages within 6 days prior to work.

M-55 AT M-66 CLOSURE	BEGINS DAY TIME
----------------------------	-----------------------

D. Display the following two messages during work.

M-55 AT M-66 CLOSURE	FOLLOW DETOUR
----------------------------	------------------

j. Traffic Signals.

1. Coordinate the modification of existing traffic signals with the Engineer.

k. Mobile Attenuators.

1. Mobile attenuators (MA's) have been included in this project.

l. Temporary Pavement Markings.

1. Replace all existing pavement markings that are removed for traffic control or obliterated during construction.

m. Measurement and Payment. Payment will be in accordance with the standard specifications unless otherwise specified. No additional payment will be made for the following activities:

1. Transporting traffic control items from site to site.
2. Providing sufficient vehicles and staff to make changes as-needed on site during work.
3. Providing sufficient vehicles and staff to remove closures from the roadway.

TYPICAL NUMBER KEY

CODES

AB= ARROW BOARD
 AW = ADVANCE WARNING
 C = CLOSURE
 CLT = CENTER LEFT TURN LANE
 CROSS= CROSSOVER
 CruSho = CRUSH AND SHAPE
 EM = EARLY MERGE
 EnR = ENTRANCE RAMP
 ExR = EXIT RAMP
 FW = FREEWAY
 GEN = GENERAL INFORMATION
 GORE= FREEWAY GORE AREA
 IN = INSIDE
 INT = INTERSECTION
 L = LANE
 (LI = LEFT
 LC= LANE CLOSURE
 LD = LONG DURATION

LO = LANE OPEN
 O = OUTSIDE (LANE CLOSURE)
 OUT = OUTSIDE OF SHOULDER
 MID = MIDDLE OF INTERSECTION OR ROAD
 NFW = NON-FREEWAY
 PARK = PARKING LANE
 PCMS = PORTABLE CHANGEABLE MESSAGE SIGN
 (R) = RIGHT
 ROLL = ROLLING ROADBLOCK
 RUM = RUMBLE STRIP
 SD= SHORT DURATION
 SHL = SHOULDER CLOSURE
 SIGN = SIGN
 SP = SPECIAL
 SPEED = SPEED
 STA = STOPPED TRAFFIC ADVISORY
 TR= TRAFFIC REGULATOR
 TS = TEMPORARY SIGNAL
 ZIP = ZIPPER MERGE

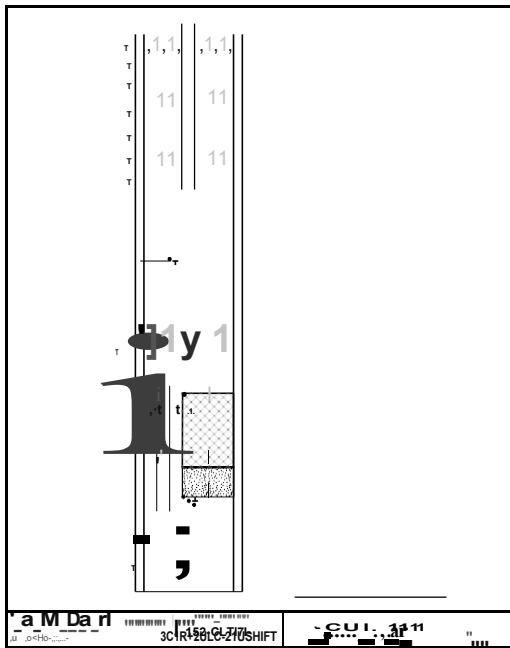

- 100 - GENERAL NOTES
- 110 - TRAFFIC REGULATORS
- 120 - NON-FREEWAY
- 130 - CENTER LEFT TURN (CLTI) LANES
- 140 - PARKING LANES
- 150 - CLT 7 LANE SECTIONS
- 150 - SIGNAL WORK
- 200 - FREEWAY CLOSURES
- 210 - FREEWAY LANE SHIFTS
- 220 - FREEWAY ENTRANCE RAMP
- 230 - FREEWAY EXIT RAMP
- 300 - ADVANCE WARNINGS
- 310 - CROSSOVER CLOSURE
- 320 - CRUSH AND SHAPE
- 340 - MERGE SYSTEMS
- 350 - GORE LOCATIONS
- 350 - ROLLING ROADBLOCK
- 4000 - MAINTENANCE
- 5000 - SURVEY

EXAMPLE TYPICAL

CODE: 152-CTU7I-311R+2LILC-21LISHIFT

152 - TYPICAL NUMBER

CTL(7) = CENTER LEFT TURN LANE, 7 LANES TOTAL.

3(1R+2LILC = 3 LANES CLOSED, (1 RIGHT LANE AND 2 LEFT LANES).

2(LISHIFT = 2 LANES SHIFTED TO THE LEFT.

NOT TO SCALE

tt.MDOT Michigan Department of Transportation	NOT TO SCALE	MAINTAINING TRAFFIC TYPICAL	TYPICAL NUMBERING KEY	DATE: <u>DECEMBER 2021</u>
		NO. 100-GEN-KEY		SHEET:
FILE: 100-GEN-KEY.dgn				1 OF 1

DISTANCE BETWEEN TRAFFIC SIGNS, "D"

"D" DISTANCES	POSTED SPEED LIMIT, MPH (PRIOR TO WORK AREA)										
	25	30	35	40	45	50	55	60	65	70	75
D (FEET)	250	300	350	400	450	500	550	600	650	700	750

GUIDELINES FOR LENGTH OF LONGITUDINAL BUFFER SPACE, "B"

"B" LENGTHS	SPEED*, MPH (PRIOR TO WORK AREA)											
	20	25	30	35	40	45	50	55	60	65	70	75
B (FEET)	33	50	83	132	181	230	279	329	411	476	542	625

* POSTED SPEED, OFF-PEAK 85TH PERCENTILE SPEED PRIOR TO WORK STARTING, OR THE ANTICIPATED OPERATING SPEED.

MINIMUM MERGING TAPER LENGTH, "L" (FEET)

OFFSET (FEET)	POSTED SPEED LIMIT, MPH (PRIOR TO WORK AREA)										
	25	30	35	40	45	50	55	60	65	70	75
1	11	15	21	27	45	50	55	60	65	70	75
2	21	30	41	54	90	100	110	120	130	140	150
3	32	45	62	80	135	150	165	180	195	210	225
4	42	60	82	107	180	200	220	240	260	280	300
5	53	75	103	134	225	250	275	300	325	350	375
6	63	90	123	160	270	300	330	360	390	420	450
7	73	105	143	187	315	350	385	420	455	490	525
8	84	120	164	214	360	400	440	480	520	560	600
9	94	135	184	240	405	450	495	540	585	630	675
10	105	150	205	267	450	500	550	600	650	700	750
11	115	165	225	294	495	550	605	660	715	770	825
12	125	180	245	320	540	600	660	720	780	840	900
13	136	195	266	347	585	650	715	780	845	910	975
14	146	210	286	374	630	700	770	840	910	980	1050
15	157	225	307	400	675	750	825	900	975	1050	1125

NOT TO SCALE

THE FORMULAS FOR THE MINIMUM LENGTH OF A MERGING TAPER IN DERIVING THE "L" VALUES SHOWN IN THE ABOVE TABLES ARE AS FOLLOWS:

"L" = $\frac{W \times S^2}{60}$ WHERE POSTED SPEED PRIOR TO THE WORK AREA IS 40 MPH OR LESS

"L" = $W \times S$ WHERE POSTED SPEED PRIOR TO THE WORK AREA IS 45 MPH OR GREATER

L = MINIMUM LENGTH OF MERGING TAPER
 S = POSTED SPEED LIMIT IN MPH PRIOR TO WORK AREA
 W = WIDTH OF OFFSET

TYPES OF TAPERS

UPSTREAM TAPERS

- MERGING TAPER
- SHIFTING TAPER
- SHOULDER TAPER
- 2 TO 1 LANE ROAD TAPER

TAPER LENGTH

- 112 L - MINIMUM
- 1/3 L - MINIMUM
- 100' - MAXIMUM
- 100' (PER LANE)

DOWNSTREAM TAPERS
 (USE IS RECOMMENDED)

MAXIMUM SPACING FOR CHANNELIZING DEVICES

WORK ZONE SPEED LIMIT	DRUM AND 42" DEVICE SPACING (FT)		NIGHTTIME 42" DEVICE SPACING (FT)	
	TAPER	TANGENT	TAPER	TANGENT
< 45 MPH	1 x SPEED LIMIT	2 x SPEED LIMIT	25 FEET	50 FEET
≥ 45 MPH	50 FEET	100 FEET	25 FEET	50 FEET

SIGN OUTLINE KEY

DASHED OUTLINES INDICATE A SIGN THAT EXISTS ON SITE, AND NEEDS TO BE COVERED.

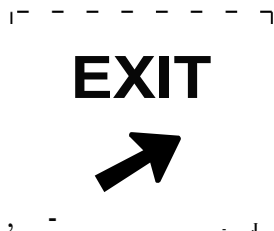

SOLID OUTLINES INDICATE A SIGN THAT IS TO BE PLACED ON THE PROJECT

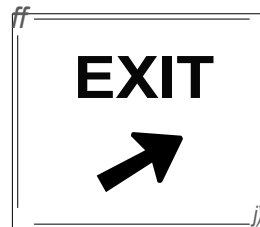

NOT TO SCALE

tt.MDOT Michigan Department of Transportation FILE: 101 -GEN-SPACING-CHART S.dgn	NOT TO SCALE	MAINTAINING TRAFFIC TYPICAL	'B', 'D' AND 'L' TABLES CHANNELIZING DEVICE SPACING SIGN BORDER KEY AND ROLL-AHEAD SPACING	DATE: MAY 2021
		NO. 101-GEN-SPACING-CHART S		SHEET: 2 OF 3

GUIDELINES FOR ROLL-AHEAD DISTANCES FOR TMA VEHICLES - TEST LEVEL 2

WEIGHT OF TMA VEHICLE	PREVAILING SPEED (POSTED SPEED PRIOR TO WORK ZONE)	ROLL-AHEAD DISTANCE* (DISTANCE FROM FRONT OF TMA VEHICLE TO WORK AREA)
5.5 TONS (STATIONARY)	40 MPH OR LESS	25 FT

* ROLL-AHEAD DISTANCES ARE CALCULATED USING A 14,410 POUND IMPACT VEHICLE WEIGHT.

GUIDELINES FOR ROLL-AHEAD DISTANCES FOR TMA VEHICLES - TEST LEVEL 3

WEIGHT OF TMA VEHICLE	PREVAILING SPEED (POSTED SPEED PRIOR TO WORK ZONE)	ROLL-AHEAD DISTANCE* (DISTANCE FROM FRONT OF TMA VEHICLE TO WORK AREA)
5 TONS (MOBILE)	45 MPH	100 FT
	50-55 MPH	150 FT
	60-75 MPH	175 FT
12 TONS (STATIONARY)	45 MPH	25 FT
	50-55 MPH	25 FT
	60-75 MPH	50 FT

* ROLL-AHEAD DISTANCES ARE CALCULATED USING A 10,000 POUND IMPACT VEHICLE WEIGHT.

THE FOLLOWING NOTES APPLY IF CALLED FOR ON THE TRAFFIC TYPICAL

GENERAL NOTES

- G1: SEE GEN-SPACING-CHARTS FOR COMMON VALUES INCLUDING:
 D DISTANCE BETWEEN TRAFFIC CONTROL DEVICES
 L MINIMUM LENGTH OF TAPER
 B LENGTH OF LONGITUDINAL BUFFER
 ROLL AHEAD DISTANCE
- G2: DISTANCE BETWEEN SIGNS, "D", THE VALUES FOR WHICH ARE SHOWN IN TYPICAL GEN-KEY ARE APPROXIMATE AND MAY NEED ADJUSTING AS DIRECTED BY THE ENGINEER.
- G3: ALL TEMPORARY SIGNS, TYPE III BARRICADES, THEIR SUPPORT SYSTEMS AND LIGHTING MUST MEET NATIONAL COOPERATIVE HIGHWAY RESEARCH PROGRAM REPORT 350 INCHRP 3501 TEST LEVEL 3, OR MANUAL FOR ASSESSING SAFETY HARDWARE IMASHI TL-3 AS WELL AS THE CURRENT EDITION OF THE MICHIGAN MANUAL ON UNIFORM TRAFFIC CONTROL DEVICES, THE CURRENT EDITION OF THE STANDARD SPECIFICATIONS FOR CONSTRUCTION, THE STANDARD PLANS AND APPLICABLE SPECIAL PROVISIONS. ONLY DESIGNS AND MATERIALS APPROVED BY MDOT WILL BE ALLOWED.
- G4: DO NOT STORE EQUIPMENT, MATERIALS OR PERFORM WORK IN ESTABLISHED BUFFER AREAS.
- G5: ALL EXISTING PAVEMENT MARKINGS WHICH ARE IN CONFLICT WITH EITHER PROPOSED CHANGES IN TRAFFIC PATTERNS OR PROPOSED TEMPORARY TRAFFIC MARKINGS SHALL BE REMOVED BEFORE ANY CHANGE IS MADE IN THE TRAFFIC PATTERN. EXCEPTION WILL BE MADE FOR TRAFFIC PATTERNS FOR WORK LESS THAN THREE DAYS THAT ARE ADEQUATELY DELINEATED BY OTHER TRAFFIC CONTROL DEVICES.

SIGN NOTES

- S1: ALL NON-APPLICABLE SIGNING WITHIN THE CIA MUST BE MODIFIED TO FIT CONDITIONS, COVERED, OR REMOVED. FOR GUIDANCE SEE THE WORK ZONE SAFETY AND MOBILITY MANUAL, SECTIONS 6.01.09 AND 6.01.10.
- S2: R5-18b SIGNS ARE ONLY REQUIRED ON FREEWAY PROJECTS WITH A DURATION OF 15 DAYS OR LONGER OR NON-FREEWAY PROJECTS WITH A DURATION OF 90 DAYS OR LONGER. TO APPLY THIS TYPICAL WITHOUT R5-18b SIGNS, REMOVE THE SIGNS AND CONSOLIDATE THE SEQUENCE AS APPROPRIATE.
- S3: R5-18c IS ONLY REQUIRED IN THE INITIAL SIGNING SEQUENCE IN THE WORK ZONE. OMIT THIS SIGN IN SUBSEQUENT SEQUENCES IN THE SAME WORK ZONE.
- S4: ADDITIONAL SIGNING AND/OR ELONGATED SIGNING SEQUENCES SHOULD BE USED WHEN TRAFFIC VOLUMES ARE SIGNIFICANT ENOUGH TO CREATE BACKUPS BEYOND THE W20-5 SIGNS.
- S5: PLACE ADDITIONAL SPEED LIMIT SIGNS REFLECTING THE WORK ZONE SPEED AFTER EACH MAJOR CROSSROAD THAT INTERSECTS THE WORK ZONE, OR AFTER EACH ENTRANCE RAMP THAT COMES ONTO THE FREEWAY WHERE THE REDUCED SPEED IS IN EFFECT. PLACE ADDITIONAL SPEED LIMIT SIGNS AT INTERVALS ALONG THE ROADWAY SUCH THAT NO SPEED LIMIT SIGNS ARE MORE THAN 2 MILES APART. WHEN REDUCED SPEED LIMITS ARE UTILIZED IN THE WORK AREA, PLACE ADDITIONAL SPEED LIMIT SIGNS RETURNING TRAFFIC TO ITS NORMAL SPEED BEYOND THE LIMITS OF THE WORK AREA AS INDICATED. IF PERMANENT SIGNS DISPLAYING THE CORRECT SPEED LIMIT ARE POSTED, OMIT ALL W3-5b AND R2-1 SIGNS AND REDUCE SPACING ACCORDINGLY
- S6: FABRICATE SPECIAL SIGNS IN ACCORDANCE WITH CURRENT SIGNING DESIGN STANDARDS.
- S7: PLACE ADDITIONAL RS-3 SIGNS AT A MAXIMUM 500' SPACING THROUGHOUT THE WORK ZONE.
- S8: WHEN SPEED LIMIT SIGNS CANNOT BE PLACED SIDE BY SIDE AS SHOWN, PLACE THEM "D" DISTANCE APART.
- S9: STOP SIGNS NOT REQUIRED IF SIGNALS ARE ON 4-WAY FLASHING RED. STOP AHEAD SIGNS ARE NOT REQUIRED IF THERE IS ADEQUATE VISIBILITY OF THE STOP SIGN OR IF SIGNALS ARE BEING USED TO CONTROL TRAFFIC.
- SI 0: PLACE REDUCED SPEED ZONE AHEAD SIGN IW3-5b HERE WHEN USING A SPEED REDUCTION IN THIS DIRECTION.
- SI 1 THE NUMBER OF W1-6 SHIFT SIGNS TO PLACE FOR A SHIFT IS AS FOLLOWS:
 SHIFTS 4FT OR LESS, PLACE ONE W1-61R1LI
 SHIFTS 5FT TO 12FT, PLACE TWO W1-61R1LI
 SHIFTS MORE THAN 12FT, PLACE THREE OR MORE W1-61R1LI SIGNS DEPENDING UPON LENGTH OF SHIFT AND AS PER THE ENGINEER.
- S12: PLACE R2-1 SIGNS AS DETAILED IN NOTE S5 WHEN THERE IS A SPEED REDUCTION IN THIS DIRECTION

TRAFFIC REGULATOR NOTES

- TR1: TRAFFIC REGULATORS MUST FOLLOW ALL THE REQUIREMENTS IN THE STANDARD SPECIFICATIONS, THE STANDARD PLANS AND APPLICABLE SPECIAL PROVISIONS, THE CURRENT VERSIONS OF THE TRAFFIC REGULATOR'S INSTRUCTION MANUAL AND THE VIDEO "HOW TO SAFELY REGULATE TRAFFIC IN MICHIGAN". THE MAXIMUM DISTANCE BETWEEN THE TRAFFIC REGULATORS IS DETERMINED BY THE ROADWAY ADT, GEOMETRICS, AND AS DIRECTED BY THE ENGINEER.
- TR2: PROVIDE APPROPRIATE BALLOON LIGHTING TO SUFFICIENTLY ILLUMINATE TRAFFIC REGULATOR'S STATIONS WHEN TRAFFIC REGULATING IS ALLOWED DURING THE HOURS OF DARKNESS.

TEMPORARY TRAFFIC CONTROL DEVICE NOTES

- TCDI: THE MAXIMUM DISTANCE IN FEET BETWEEN CHANNELIZING DEVICES IN A TAPER SHOULD NOT EXCEED 1.0 TIMES THE WORK ZONE SPEED LIMIT IN MPH FOR ROADWAYS WITH A POSTED WORK ZONE SPEED LIMIT LESS THAN 45 MPH AND SHOULD NOT EXCEED 50 FEET ON ROADWAYS WITH A POSTED WORK ZONE SPEED LIMIT OF 45 MPH OR GREATER. THE SPACING FOR 42 INCH CHANNELIZING DEVICE TAPERS ARE NOT TO EXCEED 25 FEET AT NIGHT.
- TCD2 THE MAXIMUM DISTANCE IN FEET BETWEEN CHANNELIZING DEVICES IN A TANGENT SHOULD NOT EXCEED TWICE THE WORK ZONE SPEED LIMIT IN MPH FOR ROADWAYS WITH A POSTED WORK ZONE SPEED LIMIT LESS THAN 45 MPH AND SHOULD NOT EXCEED 100 FEET ON ROADWAYS WITH A POSTED WORK ZONE SPEED LIMIT OF 45 MPH OR GREATER. THE SPACING FOR 42 INCH CHANNELIZING DEVICE TANGENTS ARE NOT TO EXCEED 50 FEET AT NIGHT.
- TCD3 TYPE III BARRICADES MUST BE LIGHTED FOR OVERNIGHT CLOSURES.
- TCD4 WHEN THE HAUL ROAD IS NOT IN USE, PLACE LIGHTED TYPE III BARRICADES WITH "ROAD CLOSED" EXTENDING COMPLETELY ACROSS THE HAUL ROAD.
- TCD5 USE OBJECT MARKER SIGNS IN LIEU OF THE TYPE B HIGH INTENSITY LIGHT SHOWN IN THE STANDARD PLAN FOR TEMPORARY CONCRETE BARRIER IR-53, AND R-1261 WHEN USED WITH A TEMPORARY SIGNAL SYSTEM. THE OBJECT MARKERS MUST BE A MINIMUM OF 12 INCHES IN WIDTH AND 36 INCHES IN HEIGHT AND HAVE ORANGE AND WHITE RETROREFLECTIVE SHEETING. THE RETROREFLECTIVE SHEETING MUST HAVE ALTERNATING DIAGONAL ORANGE AND WHITE STRIPES SLOPING DOWNWARD AT AN ANGLE OF 45 DEGREES IN THE DIRECTION VEHICULAR TRAFFIC IS TO PASS.
- TCD6 PLACE LIGHTED ARROW PANELS AS CLOSE TO THE BEGINNING OF TAPERS AS PRACTICAL, BUT NOT IN A MANNER THAT WILL OBSCURE OR CONFUSE APPROACHING MOTORISTS WHEN PHYSICAL LIMITATIONS RESTRICT PLACEMENT. IN CURBED SECTIONS, IF ARROW BOARD CANNOT BE PLACED BEHIND CURB, PLACE ARROW BOARD IN THE CLOSED LANE AS CLOSE TO THE BEGINNING OF TAPER AS POSSIBLE.
- TCD7 ADDITIONAL TYPE III BARRICADES MAY BE REQUIRED TO COMPLETELY CLOSE OFF ROAD FROM EDGE OF PAVEMENT TO EDGE OF PAVEMENT.
- TCD8 WHERE THE SHIFTED SECTION IS SHORTER THAN 600 FEET, A DOUBLE REVERSE CURVE SIGN IW24-11 CAN BE USED INSTEAD OF THE FIRST REVERSE CURVE SIGN, AND THE SECOND REVERSE CURVE SIGN CAN BE OMITTED.
- TCD9: RUMBLE STRIPS ARE TO BE PLACED AS SPECIFIED IN THE CONTRACT. IF NOT SPECIFIED IN THE CONTRACT, PLACE RUMBLE STRIPS AS SHOWN, AND IN ACCORDANCE WITH THE RUMBLE STRIP MANUFACTURER'S RECOMMENDATIONS. AN ARRAY OF RUMBLE STRIPS CONTAINS THREE RUMBLE STRIPS. PLACE THE RUMBLE STRIPS IN THE ARRAY AT A CONSISTENT DISTANCE, BETWEEN 10' AND 20' APART.
- TCD10: SEE THE WORK ZONE SAFETY AND MOBILITY MANUAL, PORTABLE CHANGEABLE MESSAGE SIGN GUIDELINES FOR RECOMMENDED AND CORRECT PCMS MESSAGING. STAGGER PCMS THAT ARE ON OPPOSING SIDES OF THE ROAD 1000 FEET FROM EACH OTHER.

RAMP NOTES

- RMP1: WHEN CONDITIONS ALLOW, E5-1 SIGNS MUST BE REMOVED OR COVERED AND CHANNELIZING DEVICES MUST BE POSITIONED TO ENABLE RAMP TRAFFIC TO DIVERGE IN A FREE MANNER
- RMP2: STOP AND YIELD CONDITIONS SHOULD BE AVOIDED WHENEVER PRACTICAL. WHEN CONDITIONS WARRANT, R1-1 SIGNS MAY BE USED IN PLACE OF R1-2 SIGNS. WHEN R-1 SIGNS ARE USED, W3-1 SIGNS MUST BE USED IN PLACE OF W3-2 SIGNS. CONSIDERATION SHOULD BE GIVEN TO CLOSING THE RAMP TO COMPLETE WORK TO ALLOW AN ADEQUATE MERGE DISTANCE. WORK SHOULD BE EXPEDITED TO AVOID THE STOP AND/OR YIELD CONDITIONS.

	NOT TO SCALE	MAINTAINING TRAFFIC TYPICAL	TRAFFIC TYPICALS NOTE SHEET	DATE: APRIL 2022
		NO: 102-GEN-NOTES		SHEET: 1 OF 2
FILE: 102-GEN-NOTES.dgn				

THE FOLLOWING NOTES APPLY IF CALLED FOR ON THE TRAFFIC TYPICAL

SIGNAL NOTES

- SIG1: EXISTING SIGNAL MUST BE EITHER 4-WAY FLASHING RED, BAGGED, OR TURNED OFF.
- SIG2: SIGNAL IS IN OPERATION.
- SIG3: DELINEATE THE WORK ZONE AREA WITH 28 INCH CONES FOR DAYTIME WORK, OR 42 INCH CHANNELIZING DEVICES FOR NIGHTTIME WORK.
- SIG4: THE CONTRACTOR MUST HAVE A DESIGNATED SPOTTER IF THE AERIAL BUCKET TRUCK IS LOCATED OVER ACTIVE TRAVEL LANES.
- SIG5: THE LOWEST POINT OF THE BUCKET MAY NOT TRAVEL BELOW 14 FOOT VERTICAL CLEARANCE. THE CONTRACTOR MUST UTILIZE AN ALTERNATE SET UP, OR PLACE THE INTERSECTION IN A 4 WAY STOP IF THE 14 FOOT VERTICAL CLEARANCE IS COMPROMIZED. USE TRAFFIC REGULATORS TO CONTROL TRAFFIC THROUGH THE INTERSECTION WHEN TRAFFIC IS PLACED IN A 4 WAY STOP.
- SIGG: DELINEATE THE TRUCK WITH CHANNELIZING DEVICES. THE POSITION OF THE TRUCK MAY BE MOVED TO FACILITATE WORK.

MAINTENANCE AND SURVEYING NOTES

- MS1: WHENEVER STOPPING SIGHT DISTANCE EXISTS TO THE REAR, THE SHADOW VEHICLES SHOULD MAINTAIN THE RECOMENDED DISTANCE FROM THE WORK AREA AND PROCEED AT THE SAME SPEED. THE SHADOW VEHICLE SHOULD SLOW DOWN AND TRAVEL AT A FARTHER DISTANCE TO PROVIDE ADEQUATE SIGHT DISTANCE IN ADVANCE OF VERTICAL OR HORIZONTAL CURVES.
- MS2: WORKERS OUTSIDE OF VEHICLES SHOULD WORK WITHIN 150' OF WORK VEHICLES WITH AN ACTIVATED BEACON, BETWEEN THE "BEGIN WORK CONVOY" SIGN AND THE "END WORK CONVOY" SIGN, OR BETWEEN THE "WORK ZONE BEGINS" AND "END ROAD WORK" SIGN
- MS3: WORK OR SHADOW VEHICLES WITH OR WITHOUT A TMA MAY BE USED TO SEPARATE THE WORK SPACE FROM TRAFFIC. IF USED, THE VEHICLES SHOULD BE PARKED ACCORDING TO THE ROLL AHEAD DISTANCE TABLES.
- MS4 WORK AND SHADOW VEHICLES SHALL BE APPROPRIATELY EQUIPPED WITH AN ACTIVATED AMBER BEACON.
- MS5 WHEN WORKERS ARE OUTSIDE THEIR VEHICLES IN AN EXISTING LANE WHILE A MOBILE OPERATION IS OCCURRING DURING THE NIGHTTIME HOURS, CHANNELIZING DEVICES TO DELINEATE OPEN OR CLOSED LANES AT 50 FT SPACING MUST BE USED. AN EXAMPLE OF AN OPERATION IBUT NOT LIMITED TOI IS THE LAYOUT OF CONCRETE PATCHES.
- MSG W21-G AND W20-1 SIGNS MAY BE SUBSTITUTED AS DETERMINED BY THE TYPE OF WORK TAKING PLACE AS PER THE ENGINEER.

SIGN NUMBER KEY

 E5-1f 48" x 48" 60" x 48"	 E5-2 48" x 36"	 E5-2a 48" x 36"	 E5-3 48" x 36"	 E13-1P VAR x 24"	 E13-1aP 36" x 24"	 G20-1 60" x 24"	 G20-2 48" x 24"
 G20-4 36" x 18"	 I-6a 18" x 18" 24" x 24" 30" x 30"	 M1-1 18" x 18" 24" x 24" 36" x 36" 48" x 48"	 M1-1 22.5" x 18" 30" x 24" 45" x 36" 60" x 48"	 M1-2 18" x 18" 24" x 24" 36" x 36" 48" x 48"	 M1-2 22.5" x 18" 30" x 24" 45" x 36" 60" x 48"	 M1-3 18" x 18" 24" x 24" 36" x 36" 48" x 48"	 M1-3 22.5" x 18" 30" x 24" 45" x 36" 60" x 48"
 M1-4 18" x 18" 24" x 24" 36" x 36" 48" x 48"	 M1-4 22.5" x 18" 30" x 24" 45" x 36" 60" x 48"	 M1-5 18" x 18" 24" x 24" 30" x 30" 36" x 36"	 M1-5a 18" x 18" 24" x 24"	 M1-6 18" x 18" 24" x 24" 36" x 36"	 M1-6 22.5" x 18" 30" x 24" 45" x 36"	 M3-1 12" x 6" 18" x 9" 24" x 12" 30" x 15" 36" x 18"	 M3-2 12" x 6" 18" x 9" 24" x 12" 30" x 15" 36" x 18"
 M3-3 12" x 6" 18" x 9" 24" x 12" 30" x 15" 36" x 18"	 M3-4 12" x 6" 18" x 9" 24" x 12" 30" x 15" 36" x 18"	 M4-1 12" x 6" 18" x 9" 24" x 12" 30" x 15" 36" x 18"	 M4-1a 12" x 6" 18" x 9" 24" x 12" 30" x 15" 36" x 18"	 M4-2 12" x 6" 18" x 9" 24" x 12" 30" x 15" 36" x 18"	 M4-3 12" x 6" 18" x 9" 24" x 12" 30" x 15" 36" x 18"	 M4-4 18" x 9" 24" x 12" 30" x 15" 36" x 18"	 M4-5 12" x 6" 18" x 9" 24" x 12" 30" x 15" 36" x 18"
 M4-6 12" x 6" 18" x 9" 24" x 12" 30" x 15" 36" x 18"	 M4-7 12" x 6" 18" x 9" 24" x 12" 30" x 15" 36" x 18"	 M4-7a 12" x 6" 18" x 9" 24" x 12" 30" x 15" 36" x 18"	 M4-8 12" x 6" 18" x 9" 24" x 12" 30" x 15"	 M4-8a 24" x 18"	 M4-8b 24" x 12"	 M4-9L 30" x 24" 48" x 36" 60" x 48"	 M4-9R 30" x 24" 48" x 36" 60" x 48"
 M4-9j 30" x 24" 48" x 36" 60" x 48"	 M4-9kL 30" x 30" 48" x 42" 60" x 54"	 M4-9kR 30" x 30" 48" x 42" 60" x 54"	 M4-9mL 30" x 30" 48" x 42" 60" x 54"	 M4-9mR 30" x 30" 48" x 42" 60" x 54"	 M4-9dL 12" x 18"	 M4-9dR 12" x 18"	 M4-9e 12" x 18"
 M4-9f 12" x 18"	 M4-9gL 12" x 18"	 M4-9gR 12" x 18"	 M4-9h 12" x 24"	 M4-9i 12" x 18"	 M4-10L 48" x 18"	 M4-10R 48" x 18"	 M4-11a 12" x 6" 18" x 9" 24" x 12" 30" x 15" 36" x 18"
 M5-1L 12" x 9" 21" x 15" 30" x 21"	 M5-1R 12" x 9" 21" x 15" 30" x 21"	 M5-2L 12" x 9" 21" x 15" 30" x 21"	 M5-2R 12" x 9" 21" x 15" 30" x 21"	 M5-3 12" x 9" 21" x 15" 30" x 21"	 M6-1L 12" x 9" 18" x 12" 21" x 15" 30" x 21"	 M6-1R 12" x 9" 18" x 12" 21" x 15" 30" x 21"	 M6-2L 12" x 9" 18" x 12" 21" x 15" 30" x 21"
 M6-2R 12" x 9" 18" x 12" 21" x 15" 30" x 21"	 M6-3 12" x 9" 18" x 12" 21" x 15" 30" x 21"	 M6-4 12" x 9" 18" x 12" 21" x 15" 30" x 21"	 M6-5 12" x 9" 18" x 12" 21" x 15" 30" x 21"	 M6-6L 12" x 9" 18" x 12" 21" x 15" 30" x 21"	 M6-6R 12" x 9" 18" x 12" 21" x 15" 30" x 21"	 M6-7L 12" x 9" 18" x 12" 21" x 15" 30" x 21"	 M6-7R 12" x 9" 18" x 12" 21" x 15" 30" x 21"

SEE MDOT SHS 13-WORK ZONE FOR SIGN DETAILS



NOT TO SCALE

MAINTAINING TRAFFIC TYPICAL

NO

103-GEN-SIGN











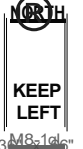
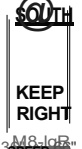

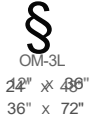





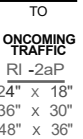



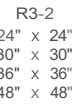

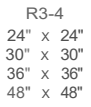











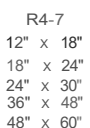
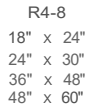



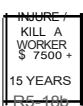







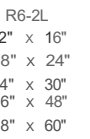
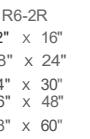

TRAFFIC TYPICALS
SIGN SHEET

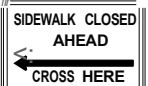
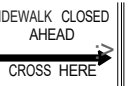
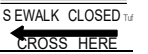
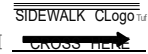
DATE: JUNE 2021

SHEET:

1 OF 5

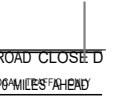
SIGN NUMBER KEY

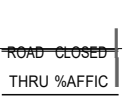
 NORTH KEEP LEFT M8-1a 36" x 36"	 SOUTH KEEP RIGHT M8-1b 36" x 36"	 M8-2a 60" x 48"	 § OM-3L 24" x 48" 36" x 72"	 OM-3R 12" x 48" 36" x 72"	 8 FRONT	 8 BACK	 RI-1 24" x 24" 30" x 30" 36" x 36" 48" x 48"	 RI-2 24" x 24"	 RI-2 24" x 24"
 TO ONCOMING TRAFFIC RI-2aP 24" x 18" 36" x 30" 48" x 36"	 LIMIT XX R2-1 18" x 24" 24" x 30" 30" x 36" 36" x 48" 48" x 60"	 R2-1a 48" x 60"	 R3-1 24" x 24" 30" x 30" 36" x 36" 48" x 48"	 R3-2 24" x 24" 30" x 30" 36" x 36" 48" x 48"	 R3-3 24" x 24" 30" x 30" 36" x 36" 48" x 48"	 R3-4 24" x 24" 30" x 30" 36" x 36" 48" x 48"	 ONLY R3-5L 30" x 36" 36" x 48"		
 ONLY R3-5R 30" x 36" 36" x 48"	 ONLY R3-5a 30" x 36" 36" x 48"	 R3-6L 30" x 36" 42" x 48"	 R3-6R 30" x 36" 42" x 48"	 LEFT LANE MUST TURN LEFT R3-7L 30" x 30" 36" x 36"	 RIGHT LANE MUST TURN RIGHT R3-7R 30" x 30" 36" x 36"	 R3-8c 36" x 30"	 R3-8d 36" x 30"		
 DO NOT PASS R4-1 12" x 18" 18" x 24" 24" x 30" 36" x 48" 48" x 60"	 PASS WITH CARE R4-2 12" x 18" 18" x 24" 24" x 30" 36" x 48" 48" x 60"	 R4-7 12" x 18" 18" x 24" 24" x 30" 36" x 48" 48" x 60"	 R4-8 18" x 24" 24" x 30" 36" x 48" 48" x 60"	 STAY IN LANE R4-9 18" x 24" 24" x 30" 36" x 48" 48" x 60"	 RS-1 30" x 30" 36" x 36" 48" x 48"	 RS-1a 30" x 30" 36" x 36" 42" x 48"	 INJURE / KILL A WORKER \$ 7500 + 15 YEARS R5-18b 48" x 60"		
 WORK ZONE BEGINS R5-18c 48" x 48"	 BEGIN WORK CONVOY R5-18d 78" x 12"	 END WORK CONVOY R5-18e 72" x 12"	 USE ALL LANES DURING BACKUPS R5-18f 48" x 60"	 FORM ONE LANE RIGHT R5-18g 30" x 42"	 DO NOT FOLLOW TRUCKS INTO WORK ZONE R5-18h 48" x 60"	 R6-1L 36" x 12" 54" x 18"			
 R6-1R 36" x 12" 54" x 18"	 R6-2L 12" x 16" 18" x 24" 24" x 30" 36" x 48" 48" x 60"	 R6-2R 12" x 16" 18" x 24" 24" x 30" 36" x 48" 48" x 60"	 R8-3 12" x 12" 18" x 18" 24" x 24" 36" x 36" 48" x 48"	 PEDESTRIAN CROSSWALK R9-9 36" x 18"	 S LEO K R9-9 24" x 12" 30" x 18"	 SIDEWALK CLOSED AHEAD USE OTHER SIDE R9-10 24" x 12" 48" x 24"	 SIDEWALK CLOSED AHEAD CROSS HERE R9-11L 24" x 12" 48" x 36"		
 R9-11R 24" x 12" 48" x 36"	 R9-11aL 24" x 12" 48" x 24"	 R9-11aR 24" x 12" 48" x 24"	 STOP HERE ON RED R10-6b 36" x 54"	 ROAD CLOSED RI-1-2 48" x 30"	 RAMP CLOSED RII-2a 48" x 30"	 EXIT CLOSED RII-2b 48" x 30"	 CROSSOVER CLOSED RII-2c 60" x 30"		
 ROAD CLOSED 1/4 MILE AHEAD RII-3a 60" x 30"	 BRIDGE OUT 1/4 MILE AHEAD RII-3b 60" x 30"	 ROAD CLOSED THRU AFFIC RII-4 60" x 30"							

SEE MDOT SHS 13-WORK ZONE FOR SIGN DETAILS

SIGN NUMBER KEY



W1-1L
18" x 18"
24" x 24"
30" x 30"
36" x 36"
48" x 48"



W1-1R
18" x 18"
24" x 24"
30" x 30"
36" x 36"
48" x 48"



W1-2L
18" x 18"
24" x 24"
30" x 30"
36" x 36"
48" x 48"



W1-2R
18" x 18"
24" x 24"
30" x 30"
36" x 36"
48" x 48"



W1-2bL
36" x 36"
48" x 48"



W1-2bR
36" x 36"
48" x 48"



W1-3L
18" x 18"
24" x 24"
30" x 30"
36" x 36"
48" x 48"



W1-3R
18" x 18"
24" x 24"
30" x 30"
36" x 36"
48" x 48"



W1-4L
18" x 18"
24" x 24"
30" x 30"
36" x 36"
48" x 48"



W1-4R
18" x 18"
24" x 24"
30" x 30"
36" x 36"
48" x 48"



W1-4bL
24" x 24"
30" x 30"
36" x 36"
48" x 48"



W1-4bR
24" x 24"
30" x 30"
36" x 36"
48" x 48"



W1-4cL
24" x 24"
30" x 30"
36" x 36"
48" x 48"



W1-4cR
24" x 24"
30" x 30"
36" x 36"
48" x 48"



W24-1L
30" x 30"
36" x 36"
48" x 48"



ALL LANES
W24-1cP
24" x 18"
30" x 24"



W24-1R
30" x 30"
36" x 36"
48" x 48"



W24-1cL
30" x 30"
36" x 36"
48" x 48"



W24-1cR
30" x 30"
36" x 36"
48" x 48"



W24-1bL
30" x 30"
36" x 36"
48" x 48"



W24-1bR
30" x 30"
36" x 36"
48" x 48"



W1-6L
24" x 12"
36" x 18"
48" x 24"
60" x 30"
96" x 48"



W1-6R
24" x 12"
36" x 18"
48" x 24"
60" x 30"
96" x 48"



W1-8L
12" x 18"
18" x 24"
24" x 30"
30" x 36"
36" x 48"



W1-8R
12" x 18"
18" x 24"
24" x 30"
30" x 36"
36" x 48"



W3-1
18" x 18"
24" x 24"
30" x 30"
36" x 36"
48" x 48"



W3-2
18" x 18"
24" x 24"
30" x 30"
36" x 36"
48" x 48"



W3-3
18" x 18"
30" x 30"
36" x 36"
48" x 48"



BE PREPARED TO STOP
W3-4
30" x 30"
36" x 36"
48" x 48"
60" x 60"



PREPARE TO STOP WHEN FLASHING
W3-4b
30" x 30"
36" x 36"
48" x 48"



W3-5
36" x 36"
48" x 48"



XX MPH SPEED ZONE AHEAD
W3-5a
30" x 30"
36" x 36"
48" x 48"
60" x 60"



REDUCED SPEED ZONE AHEAD
W3-5b
30" x 30"
36" x 36"
48" x 48"



W4-1L
24" x 24"
30" x 30"
36" x 36"
48" x 48"



W4-1R
24" x 24"
30" x 30"
36" x 36"
48" x 48"



W4-2L
30" x 30"
36" x 36"
48" x 48"



W4-2R
30" x 30"
36" x 36"
48" x 48"



W4-3L
30" x 30"
36" x 36"
48" x 48"



W4-3R
30" x 30"
36" x 36"
48" x 48"



W4-5L
24" x 24"
30" x 30"
36" x 36"
48" x 48"



W4-5R
24" x 24"
30" x 30"
36" x 36"
48" x 48"



NO MERGE AREA
W4-5P
18" x 24"
24" x 30"



W4-6L
24" x 24"
30" x 30"
36" x 36"
48" x 48"



W4-6R
24" x 24"
30" x 30"
36" x 36"
48" x 48"



THRU TRAFFIC MERGE LEFT
W4-7L
30" x 30"
36" x 36"
48" x 48"
60" x 60"



THRU TRAFFIC MERGE RIGHT
W4-7R
30" x 30"
36" x 36"
48" x 48"
60" x 60"



ROAD NARROWS
W5-1
30" x 30"
36" x 36"
48" x 48"



NARROW BRIDGE
W5-2
18" x 18"
30" x 30"
36" x 36"
48" x 48"



ONE LANE BRIDGE
W5-3
24" x 24"
30" x 30"
36" x 36"
48" x 48"



RAMP NARROWS
W5-4
30" x 30"
36" x 36"
48" x 48"



W6-1
30" x 30"
36" x 36"
48" x 48"



W6-2
30" x 30"
36" x 36"
48" x 48"



W6-3
30" x 30"
36" x 36"
48" x 48"



W6-4
12" x 18"



W7-1
24" x 24"
30" x 30"
36" x 36"
48" x 48"



W7-1a
24" x 24"
30" x 30"
36" x 36"
48" x 48"



BUMP
W8-1
18" x 18"
24" x 24"
30" x 30"
36" x 36"
48" x 48"

SEE MDOT SHS 13-WORK ZONE FOR SIGN DETAILS



NOT TO SCALE

MAINTAINING TRAFFIC TYPICAL

NO

103-GEN-SIGN























































TRAFFIC TYPICALS
SIGN SHEET

DATE: JUNE 2021

SHEET:

3 OF 5

SIGN NUMBER KEY

 W8-2 18" x 18" 24" x 24" 30" x 30" 36" x 36" 48" x 48"	 W8-3 18" x 18" 30" x 30" 36" x 36" 48" x 48"	 W8-4 18" x 18" 24" x 24" 30" x 30" 36" x 36" 48" x 48"	 W8-5 24" x 24" 30" x 30" 36" x 36" 48" x 48"	W8-5P 24" x 18" 30" x 24" 36" x 30"	 W8-7 24" x 24" 30" x 30" 36" x 36" 48" x 48"	 W8-8 24" x 24" 30" x 30" 36" x 36" 48" x 48"	 W8-9 24" x 24" 30" x 30" 36" x 36" 48" x 48"
 W8-11 24" x 24" 30" x 30" 36" x 36" 48" x 48"	 W8-12 30" x 30" 36" x 36" 48" x 48"	 W8-14 24" x 24" 30" x 30" 36" x 36" 48" x 48"	 W8-15 24" x 24" 30" x 30" 36" x 36" 48" x 48"	 W8-15P 24" x 18" 30" x 24" 36" x 30"	 W8-17L 24" x 24" 30" x 30" 36" x 36" 48" x 48"	 W8-17R 24" x 24" 30" x 30" 36" x 36" 48" x 48"	 W8-17P 24" x 18" 30" x 24" 36" x 30"
 W8-18 24" x 24" 36" x 36" 48" x 48"	 W8-23 24" x 24" 36" x 36" 48" x 48"	 W8-24 30" x 30" 36" x 36" 48" x 48"	 W8-25 24" x 24" 30" x 30" 36" x 36" 48" x 48"	W8-26 36" x 36" 48" x 48"	 W8-1L 24" x 24" 30" x 30" 36" x 36" 48" x 48"	 W8-1R 24" x 24" 30" x 30" 36" x 36" 48" x 48"	 W8-2L 30" x 30" 36" x 36" 48" x 48"
 W9-2R 30" x 30" 36" x 36" 48" x 48"	 W9-3C 30" x 30" 36" x 36" 48" x 48" 60" x 60"	 W9-3L 30" x 30" 36" x 36" 48" x 48" 60" x 60"	 W9-3R 30" x 30" 36" x 36" 48" x 48" 60" x 60"	 W9-3o 30" x 30" 36" x 36" 48" x 48" 60" x 60"	 W9-3b 30" x 30" 36" x 36" 48" x 48" 60" x 60"	 W11-10 24" x 24" 30" x 30" 36" x 36" 48" x 48"	 W11-10o 24" x 24" 30" x 30" 36" x 36" 48" x 48"
 W11-24 36" x 36" 48" x 48"	 W12-1 24" x 24" 30" x 30" 36" x 36" 48" x 48"	 W12-2 18" x 18" 30" x 30" 36" x 36" 48" x 48"	 W13-1P 18" x 18" 24" x 24" 30" x 30"	 W13-2 24" x 30" 36" x 48" 48" x 60"	 W13-3 24" x 30" 36" x 48" 48" x 60"	 W13-4P 24" x 24" 36" x 36"	 W13-6 24" x 42" 36" x 60" 48" x 84"
 W13-6o 24" x 42" 36" x 60" 48" x 84"	 W13-7 24" x 42" 36" x 60" 48" x 84"	 W13-7o 24" x 42" 36" x 60" 48" x 84"	 W14-3 36" x 24" 40" x 30" 48" x 36" 64" x 48"	 W16-2P 18" x 12" 24" x 18" 30" x 24"	 W16-4oP 18" x 12" 24" x 18" 30" x 24" 36" x 30"	 W16-12P 24" x 18"	 W16-13P 24" x 18" 30" x 24"
 W20-1 24" x 24" 30" x 30" 36" x 36" 48" x 48" 60" x 60"	 W20-1o 24" x 24" 30" x 30" 36" x 36" 48" x 48" 60" x 60"	 W20-1b 24" x 24" 30" x 30" 36" x 36" 48" x 48" 60" x 60"	 W20-1c 24" x 24" 30" x 30" 36" x 36" 48" x 48" 60" x 60"	 W20-1d 24" x 24" 30" x 30" 36" x 36" 48" x 48" 60" x 60"	 W20-2 30" x 30" 36" x 36" 48" x 48"	 W20-3 30" x 30" 36" x 36" 48" x 48"	 W20-3o 30" x 30" 36" x 36" 48" x 48"

SEE MDOT SHS 13-WORK ZONE FOR SIGN DETAILS

tt.MDOT
Michigan Department of Transportation

NOT TO SCALE

MAINTAINING TRAFFIC TYPICAL

NO.

103-GEN-SIGN

**TRAFFIC TYPICALS
SIGN SHEET**

DATE:

JUNE 2021

SHEET:

4 OF 5

SIGN NUMBER KEY



W20-3b
30" x 30"
36" x 36"
48" x 48"



W20-4
30" x 30"
36" x 36"
48" x 48"



W20-4c
36" x 36"
48" x 48"



W20-5C
30" x 30"
36" x 36"
48" x 48"



W20-5L
30" x 30"
36" x 36"
48" x 48"



W20-5L1
30" x 30"
36" x 36"
48" x 48"



W20-5L2
30" x 30"
36" x 36"
48" x 48"



W20-5R
30" x 30"
36" x 36"
48" x 48"



W20-5R1
30" x 30"
36" x 36"
48" x 48"



W20-5R2
30" x 30"
36" x 36"
48" x 48"



W20-5aL2
30" x 30"
36" x 36"
48" x 48"



W20-5aL3
30" x 30"
36" x 36"
48" x 48"



W20-5aR2
30" x 30"
36" x 36"
48" x 48"



W20-5aR3
30" x 30"
36" x 36"
48" x 48"



W20-7a
30" x 30"
36" x 36"
48" x 48"



W20-8
24" x 18"



W20-9
54" x 48"



W20-10
48" x 24"
66" x 30"

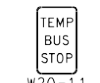

W20-11
12" x 18"

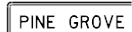

W20-12P
VARIABLE x 12"

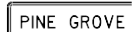

W20-13P
VARIABLE x 12"



W20-14L
36" x 36"
48" x 48"



W20-14R
36" x 36"
48" x 48"



W20-14aP
36" x 12"
48" x 12"



W20-14bP
36" x 12"
48" x 12"



W20-15
36" x 36"
48" x 48"



W20-15a
36" x 36"
48" x 48"



W20-15c
48" x 54"



W20-15d
48" x 54"



W20-16
36" x 36"
48" x 48"



W20-17
36" x 36"
48" x 48"



W21-1
24" x 24"
30" x 30"
36" x 36"
48" x 48"



W21-2
24" x 24"
30" x 30"
36" x 36"
48" x 48"



W21-2
24" x 24"
30" x 30"
36" x 36"
48" x 48"



W21-3
24" x 24"
30" x 30"
36" x 36"
48" x 48"



W21-4
36" x 18"



W21-5
24" x 24"
30" x 30"
36" x 36"
48" x 48"



W21-5aL
30" x 30"
36" x 36"
48" x 48"
60" x 60"



W21-5aR
30" x 30"
36" x 36"
48" x 48"
60" x 60"



W21-5bL
30" x 30"
36" x 36"
48" x 48"
60" x 60"



W21-5bR
30" x 30"
36" x 36"
48" x 48"
60" x 60"



W21-6
24" x 24"
30" x 30"
36" x 36"
48" x 48"



W21-7
30" x 30"
36" x 36"
48" x 48"



W21-8
30" x 30"
36" x 36"
48" x 48"



W22-1
30" x 30"
36" x 36"
48" x 48"



W22-2
42" x 36"



W22-3
36" x 30"
42" x 36"



W23-1
48" x 24"



W23-2
36" x 36"
48" x 48"

SEE MDOT SHS 13-WORK ZONE FOR SIGN DETAILS



NOT TO SCALE

MAINTAINING TRAFFIC TYPICAL

NO

103-GEN-SIGN

TRAFFIC TYPICALS
SIGN SHEET

DATE: JUNE 2021

SHEET:

5 OF 5

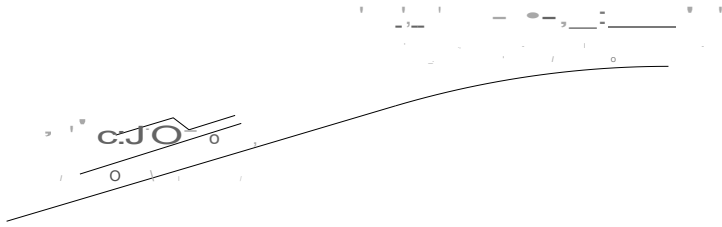

[N'coRRECT ' u'sAG-E ,

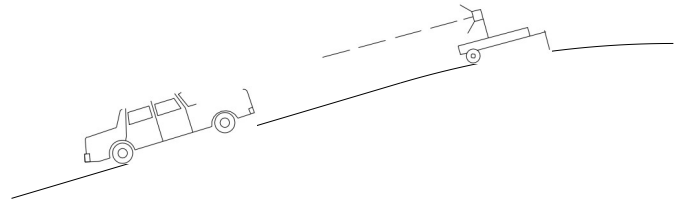

CORRECT USAGE

PLACEMENT ON A CREST VERTICAL CURVE

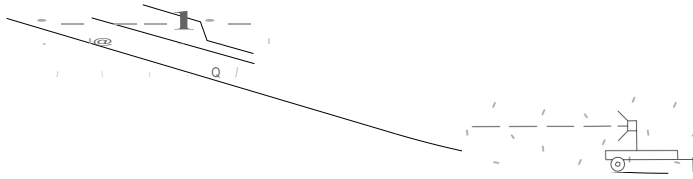

[N'coRRECT ' u'sAG-E ,

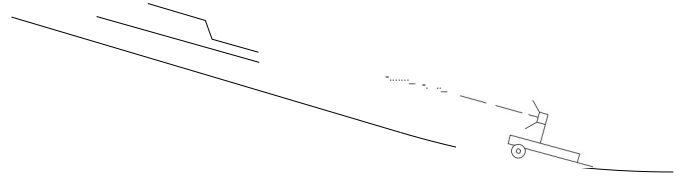

CORRECT USAGE

PLACEMENT ON A SAG VERTICAL CURVE

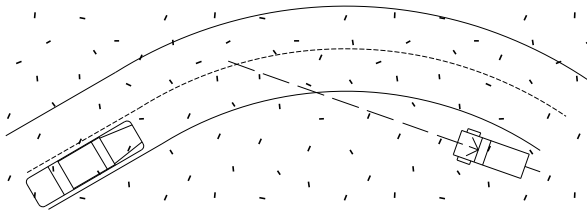

[N'coRRECT ' u'sAG-E ,

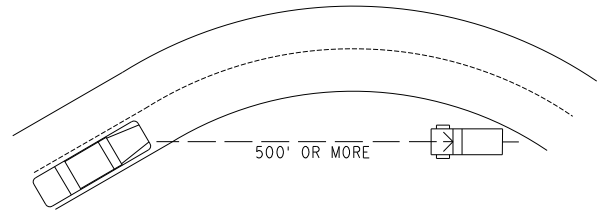

CORRECT USAGE

NOT TO SCALE

PLACEMENT ON A HORIZONTAL CURVE

NOTE:

ENSURE THE ARROW REMAINS CLEARLY LEGIBLE AT DISTANCES FROM 2,500 FEET TO 200 FEET, FROM ALL TRAFFIC LANES AND ROADWAY ENTRANCES. DO NOT PLACE THE LIGHTED ARROW ON A HORIZONTAL OR VERTICAL CURVE THAT MIGHT INTERFERE WITH THIS LEGIBILITY REQUIREMENT.

tt.MDOT Michigan Department of Transportation	NOT TO SCALE	MAINTAINING TRAFFIC TYPICAL	USE OF ARROW BOARD ON HILL OR CURVE AND WORK ZONE LAYOUT	DATE: MAY 2021
		NO: 104-GEN-AB		SHEET: 1 OF 1

NO SPEED REDUCTION THROUGH WORK ZONE

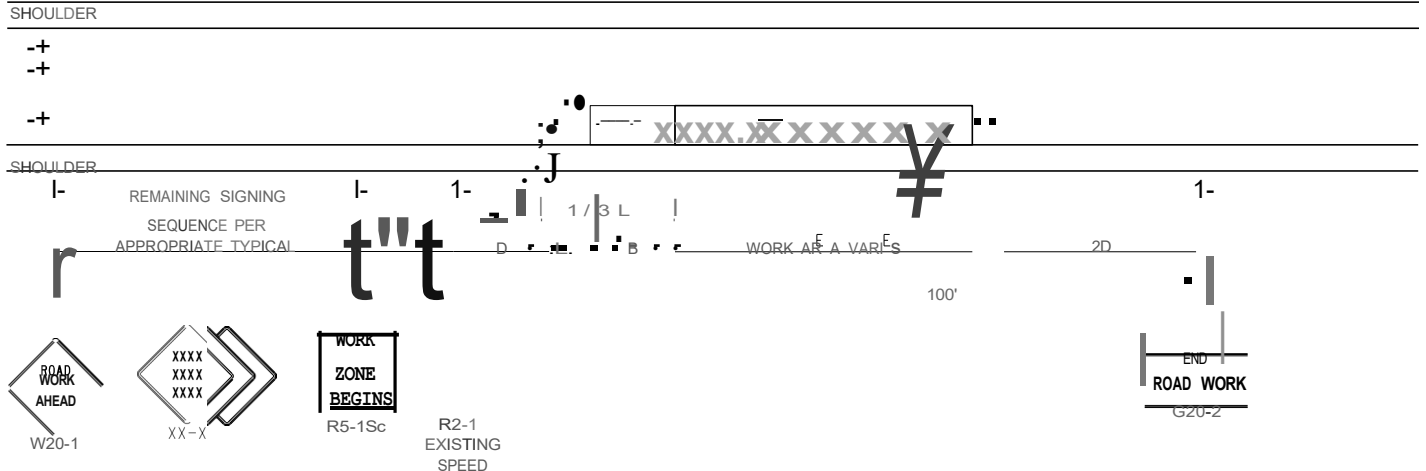

REDUCED SPEED THROUGH WORK ZONE

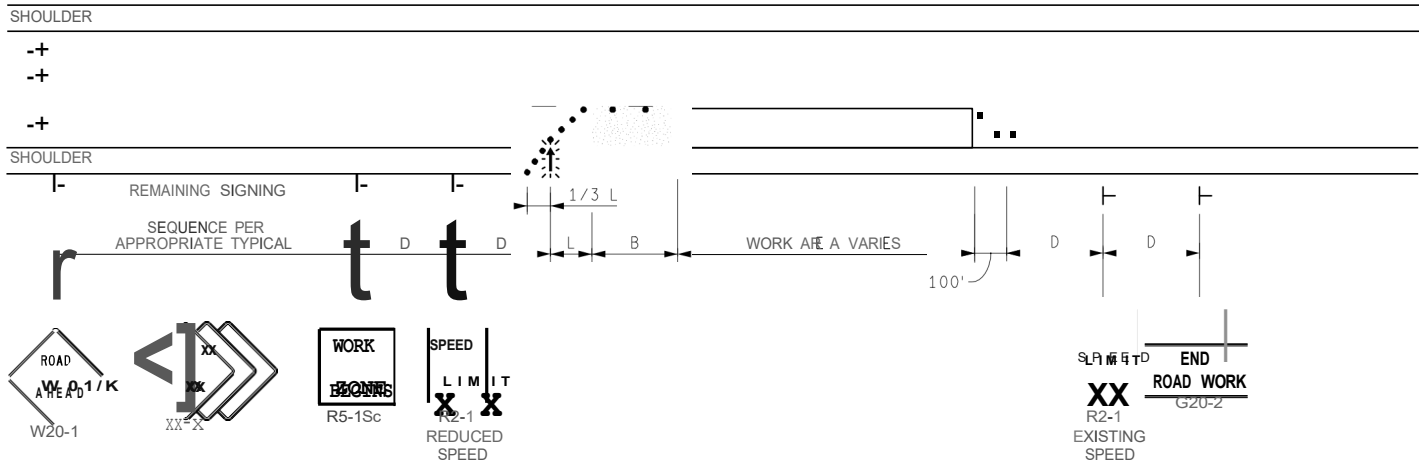

REDUCED SPEED THROUGH WORK ZONE USING "WHERE WORKERS PRESENT"

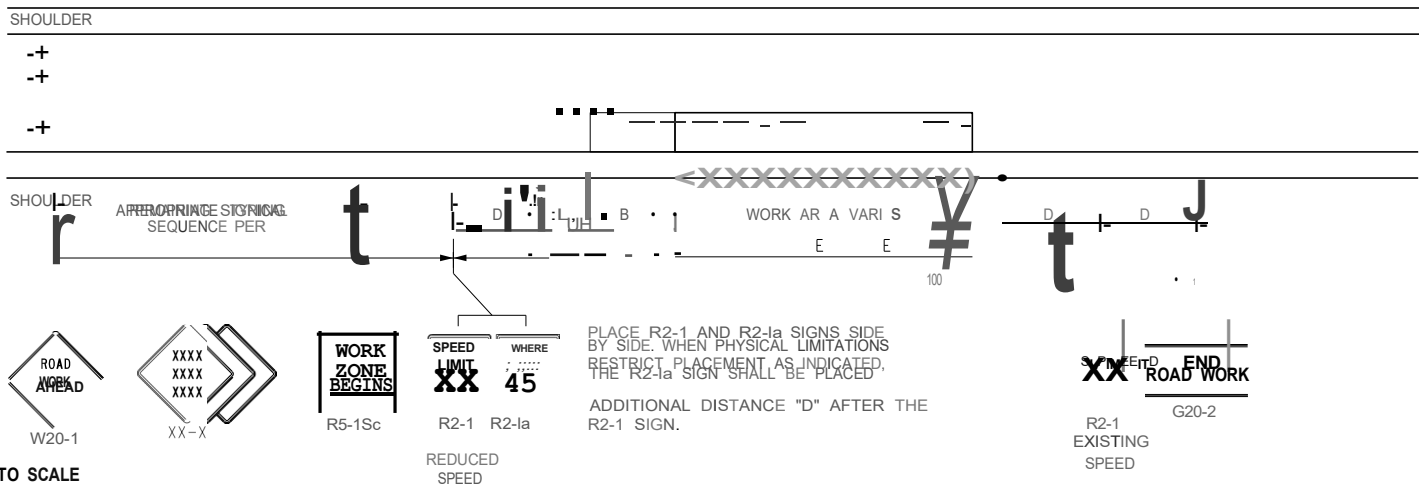

NOT TO SCALE

tt.MDOT Michigan Department of Transportation	NOT TO SCALE	MAINTAINING TRAFFIC TYPICAL	SPEED LIMIT LAYOUT	DATE: MAY 2021
		NO. 107-GEN-SPEED		SHEET:
FILE: 10 7-GEN-SPEED.dgn				1 OF 2

REDUCED SPEED FROM 75 TO 50 THROUGH WORK ZONE

SHOULDER

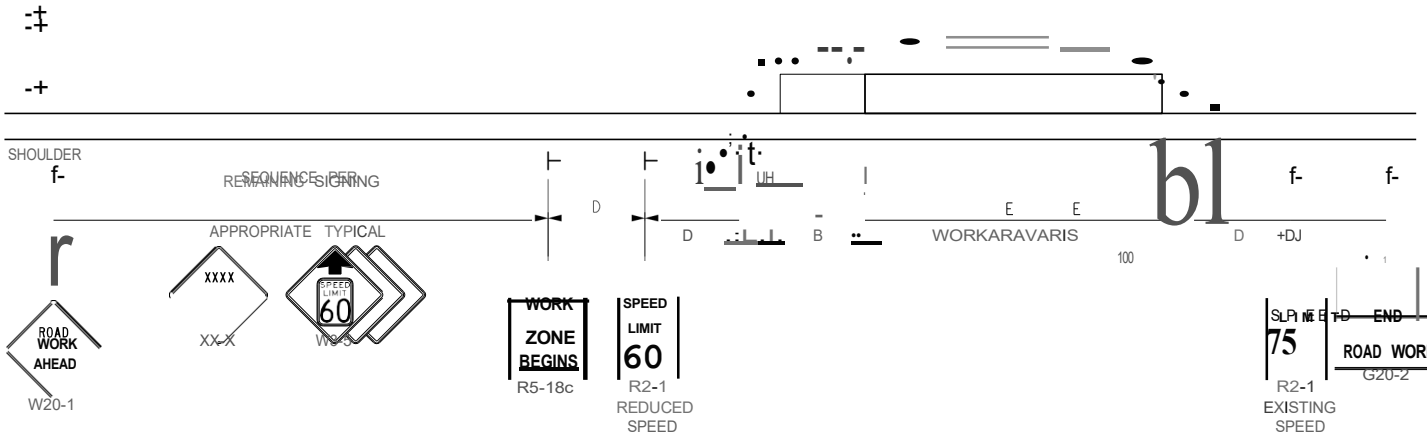

REDUCED SPEED FROM 75 TO 45 WWP THROUGH WORK ZONE

SHOULDER

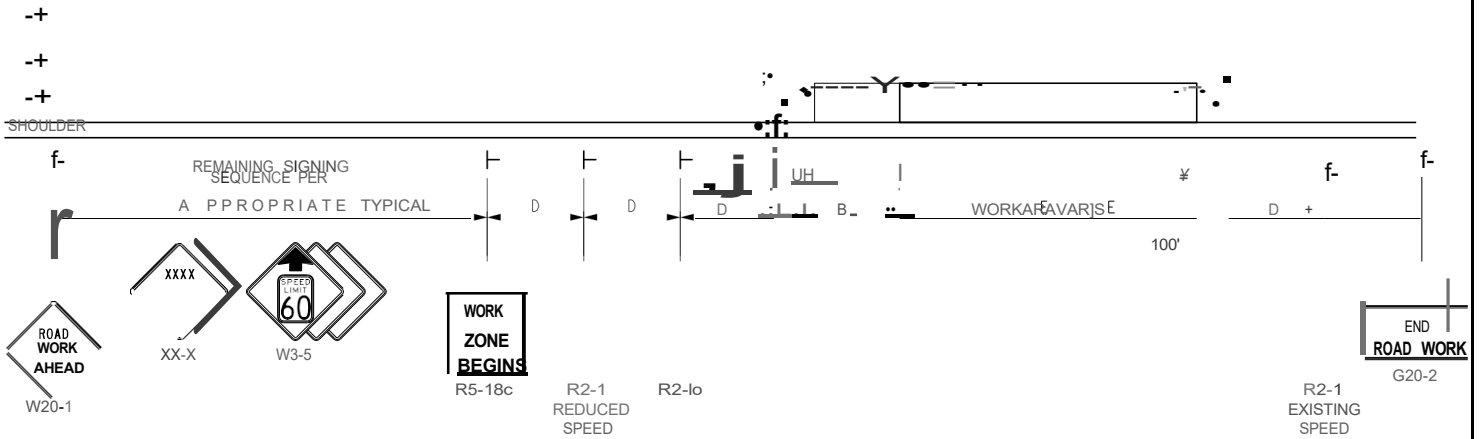

NOT TO SCALE

tt.MDOT
Michigan Department of Transportation

NOT TO SCALE

MAINTAINING TRAFFIC TYPICAL

NO:

107-GEN-SPEED

SPEED LIMIT LAYOUT

DATE: MAY 2021

SHEET:

2 OF 2

FILE: 10 7-GEN-SPEED.dgn

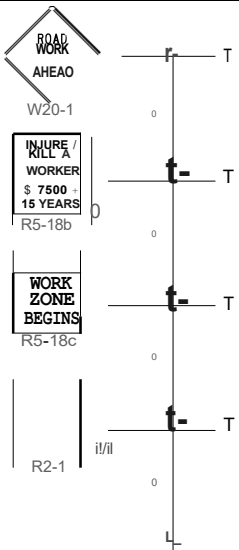

! It

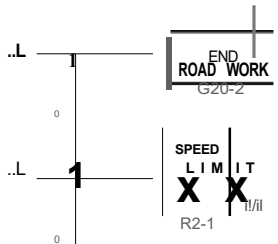

KEY

- CHANNELIZING DEVICES
- LIGHTED ARROW PANEL !CAUTION MODE!
- + - TRAFFIC FLOW
- i/i REFLECTS EXISTING SPEED LIMIT
- 0 PLACE SIGN AS INDICATED IN NOTE S2

STANDARD NOTES

ISEE 102-GEN-NOTES!
 GENERAL: G1, G2, G3, G4
 SIGNING S1, S2, S3, S5
 DEVICES TCD1, TCD2, TCD6, TCD7

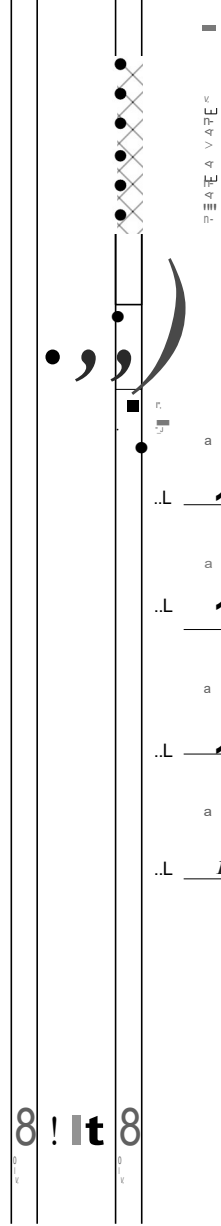
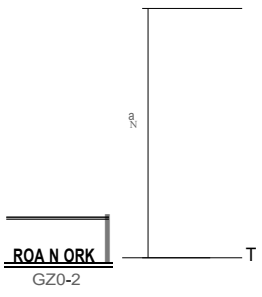

8 ! It 8

POST W16-4aP WHEN SHOULDER CLOSURE EXCEEDS 1 MILE IN LENGTH

tt.MDOT Michigan Department of Transportation FILE: 122-NFW-SHL-IRI.dgn	NOT TO SCALE	MAINTAINING TRAFFIC TYPICAL	SHOULDER CLOSURE ON A 2-LANE, UNDIVIDED ROADWAY	DATE: MAY 2021
		NO. 122-NFW-SHL -(R)		SHEET: 1 OF 1

KEY

- CHANNELIZING DEVICES
- ← TRAFFIC FLOW
- REFLECTS EXISTING SPEED LIMIT
- PLACE SIGN AS INDICATED IN NOTE S5
- PLACE SIGN AS INDICATED IN NOTE S2

STANDARD NOTES

(SEE 102-GEN-NOTES)

GENERAL: G1, G2, G3, G4, G5
 SIGNING: S1, S2, S3, S5, S10, S11, S12
 DEVICES: TCD1, TCD2, TCD8

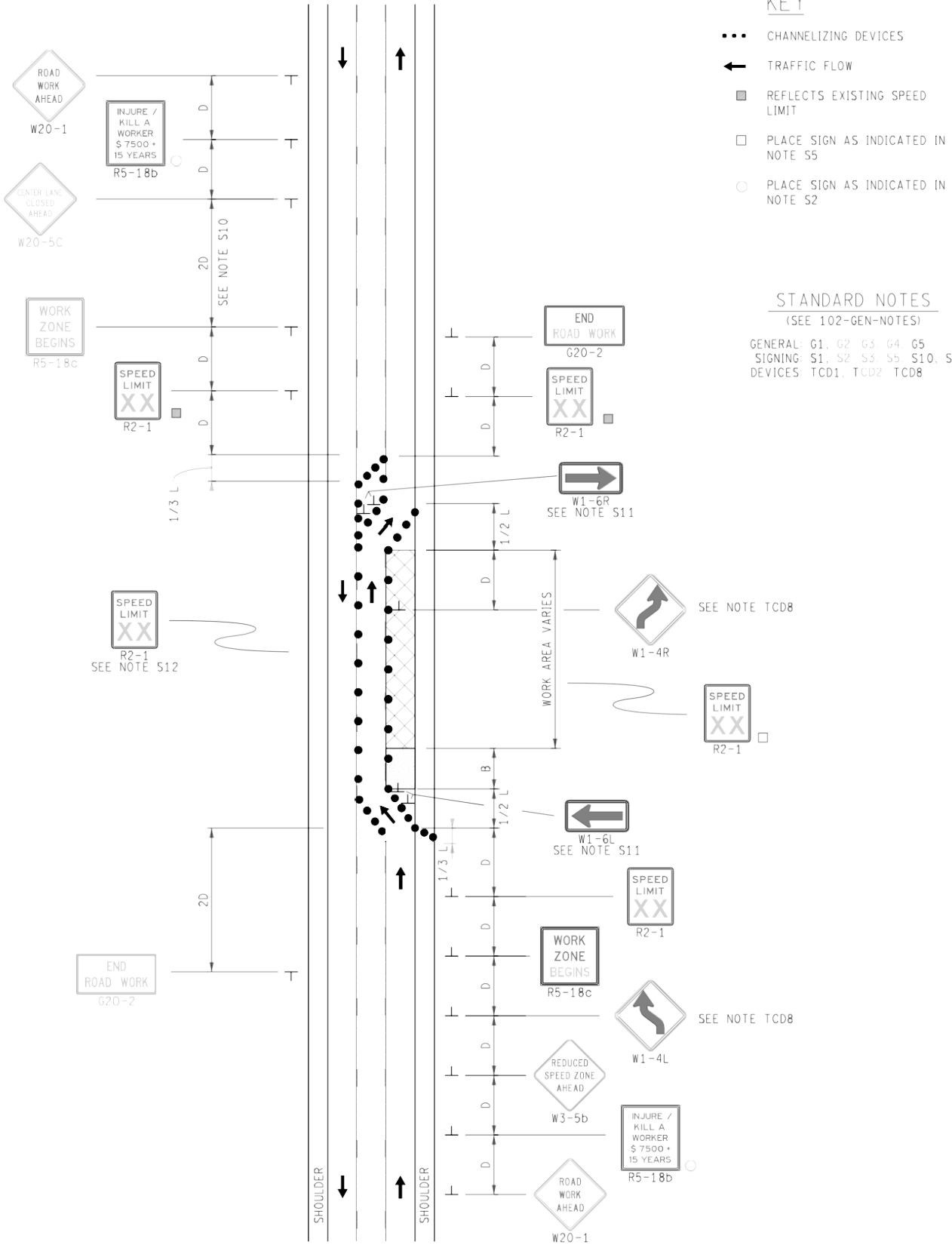

NOT TO SCALE

MAINTAINING TRAFFIC TYPICAL

NO
 137-CLT-SHIFT-OLC

LANE SHIFT
 ON A 3-LANE UNDIVIDED ROADWAY

DATE: DECEMBER 2021
 SHEET:

SIGN MATERIAL SELECTION TABLE

SIGN MATERIAL TYPE			
SIGN SIZE	TYPE I	TYPE II	TYPE III
36" X 36"		X	X
>36" X 36" <_ 96" TO WIDE		X	
>96" WIDE TO 144" WIDE	X	X	
> 144" WIDE	X		

TYPE I ALUMINUM EXTRUSION
 TYPE II PLYWOOD
 TYPE III ALUMINUM SHEET

ROUNDING OF CORNERS IS NOT REQUIRED FOR TYPE I OR II SIGNS.
 VERTICAL JOINTS ARE NOT PERMITTED.
 HORIZONTAL JOINTS THROUGH SIGN LEGEND OR SYMBOLS ARE NOT PERMITTED.

POST SIZE REQUIREMENTS TABLE

POST TYPE			
SIGN AREA (ft ²)	LI-CHANNEL STEEL	SQUARE TUBULAR STEEL	WOOD
9	1 - 3 lb/ft*	1 - 2" 12 or 14 GA*	N/A
9 20	2 - 3 lb/ft	2 - 2" 12 or 14 GA	1 - 4" X 6"*
> 20 30	N/A	N/A	2 - 4" X 6"
> 30 60	N/A	N/A	2 - 6" X 8"
> 60 84	N/A	N/A	3 - 6" X 8"

*SIGNS 4 FEET AND GREATER IN WIDTH REQUIRE 2 POSTS.
 SIGNS GREATER THAN 8 FEET IN WIDTH REQUIRE 2 OR 3 WOOD
 POSTS DEPENDING ON AREA OF SIGN.
 A MAXIMUM OF 2 POSTS WITHIN A 7' PATH IS PERMITTED.

 PREPARED BY DESIGN DIVISION DRAWN BY: <u>CONECH</u> CHECKED BY: <u>AI&</u>	DEPARTMENT DIRECTOR Kirk T. Steudle APPROVED BY: _____ DIRECTOR, BUREAU IF FIELD SERVICES	MICHIGAN DEPARTMENT OF TRANSPORTATION BUREAU OF DEVELOPMENT STANDARD PLAN FOR GROUND DRIVEN SIGN SUPPORTS FOR TEMP SIGNS	
	APPROVED BY: _____ DIRECTOR, BUREAU IF DEVELDPINT	F.H.U. APPROVAL	<u>11/2/2017</u> PLAN DATE

2 POST SIGN SUPPORT SPACING

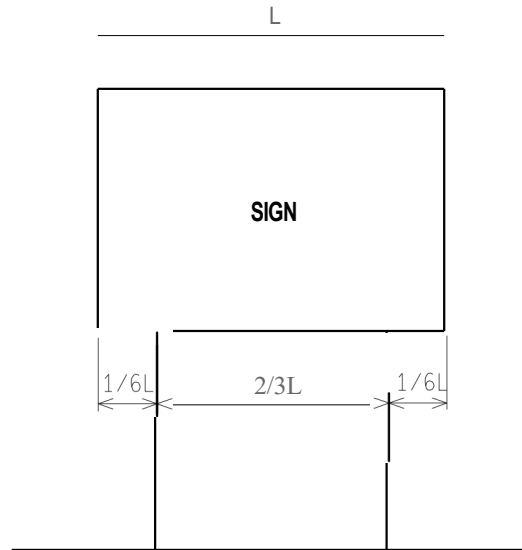

3 POST SIGN SUPPORT SPACING

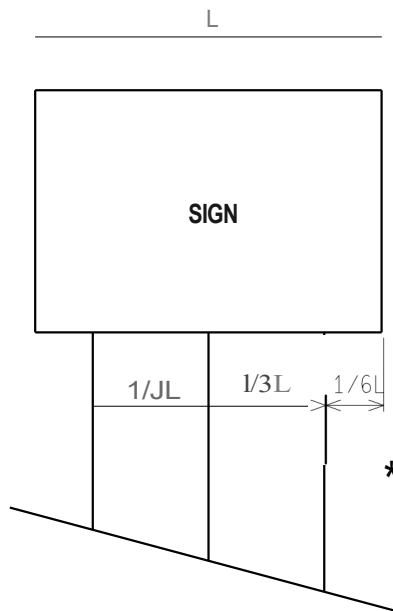

* FOR ALL 11' AND 12' LONG SIGNS ON 3 WOOD SUPPORTS, SPREAD POSTS SO AS TO HAVE A 8' MIN. TO 9' MAX. DISTANCE BETWEEN OUTSIDE POSTS.

NOT TO SCALE

MICHIGAN DEPARTMENT OF TRANSPORTATION
BUREAU OF DEVELOPMENT STANDARD PLAN

ENR. APPROVAL

PLAN DATE
11/2/2017

WZD-100-A 2 OF 11 SHEET

NOTE: THE ORIGINAL SIGNED COPY IS KEPT ON FILE AT THE MICHIGAN DEPARTMENT OF TRANSPORTATION.

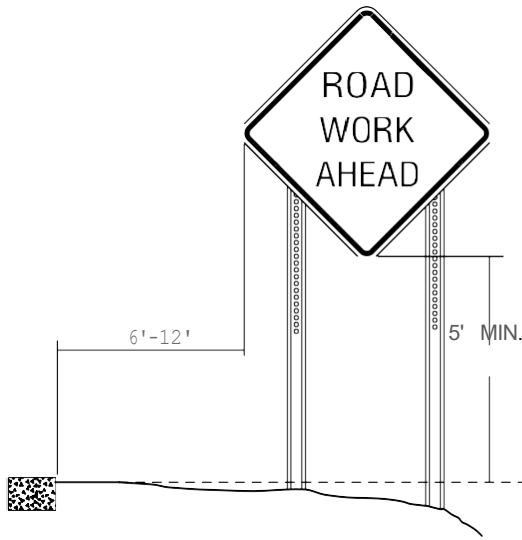

RURAL

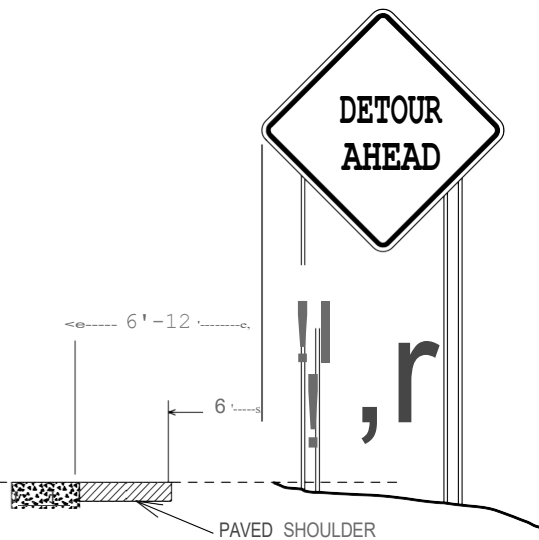

RURAL WITH ADVISORY SPEED PLATE

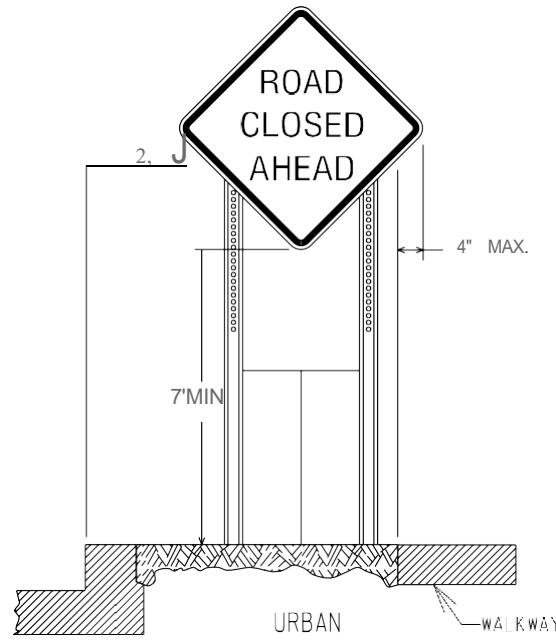

(CURBED AREAS OR WHERE WALKWAYS ARE PRESENT)

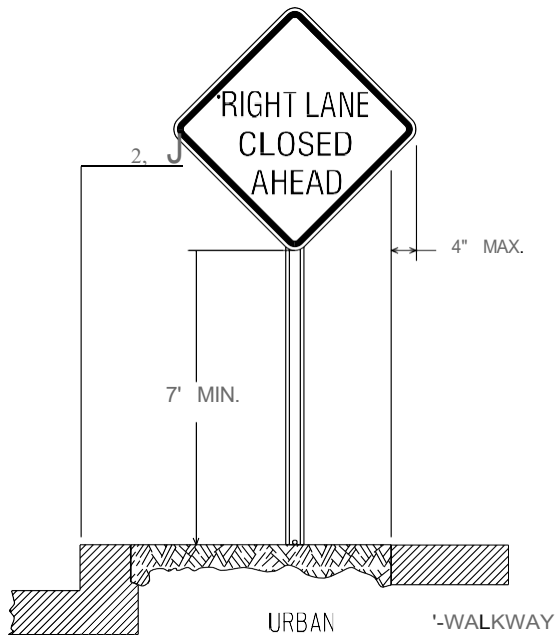

(CURBED AREAS OR WHERE WALKWAYS ARE PRESENT)

BOTTOM HEIGHT AND OFFSET

NOT TO SCALE

MICHIGAN DEPARTMENT OF TRANSPORTATION BUREAU OF DEVELOPMENT STANDARD PLAN	f.H.w.A. APPROVAL	11/2/2017 PLAN DATE	WZD-100-A	SHEET 3 OF 11
--	-------------------	------------------------	-----------	------------------

NOTE: THE ORIGINAL SIGNED COPY IS KEPT ON FILE AT THE MICHIGAN DEPARTMENT OF TRANSPORTATION.

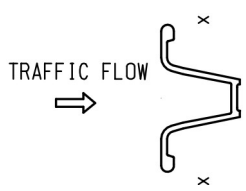
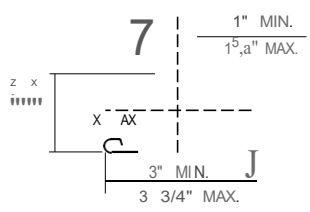
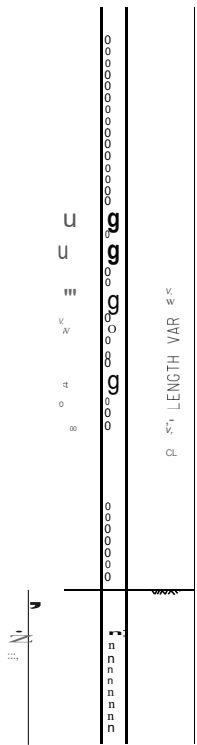

WEIGHT= 3 lbs/ft
 SECT. MOO. X.-X. = 0.31 CUBIC INCHES MIN.

3 lb. U - CHANNEL STEEL POST
(NO SPLICE)

MOUNT SIGN ON OPEN FACE OF
 U - CHANNEL STEEL POST

NOT TO SCALE

MICHIGAN DEPARTMENT OF TRANSPORTATION BUREAU OF DEVELOPMENT STANDARD PLAN	F.H.W.A. APPROVAL	11/2/2017 PLAN DATE	WZD-100-A	SHEET 4 OF 11
--	-------------------	------------------------	------------------	------------------

NOTE: THE ORIGINAL SIGNED COPY IS KEPT ON FILE AT THE MICHIGAN DEPARTMENT OF TRANSPORTATION.

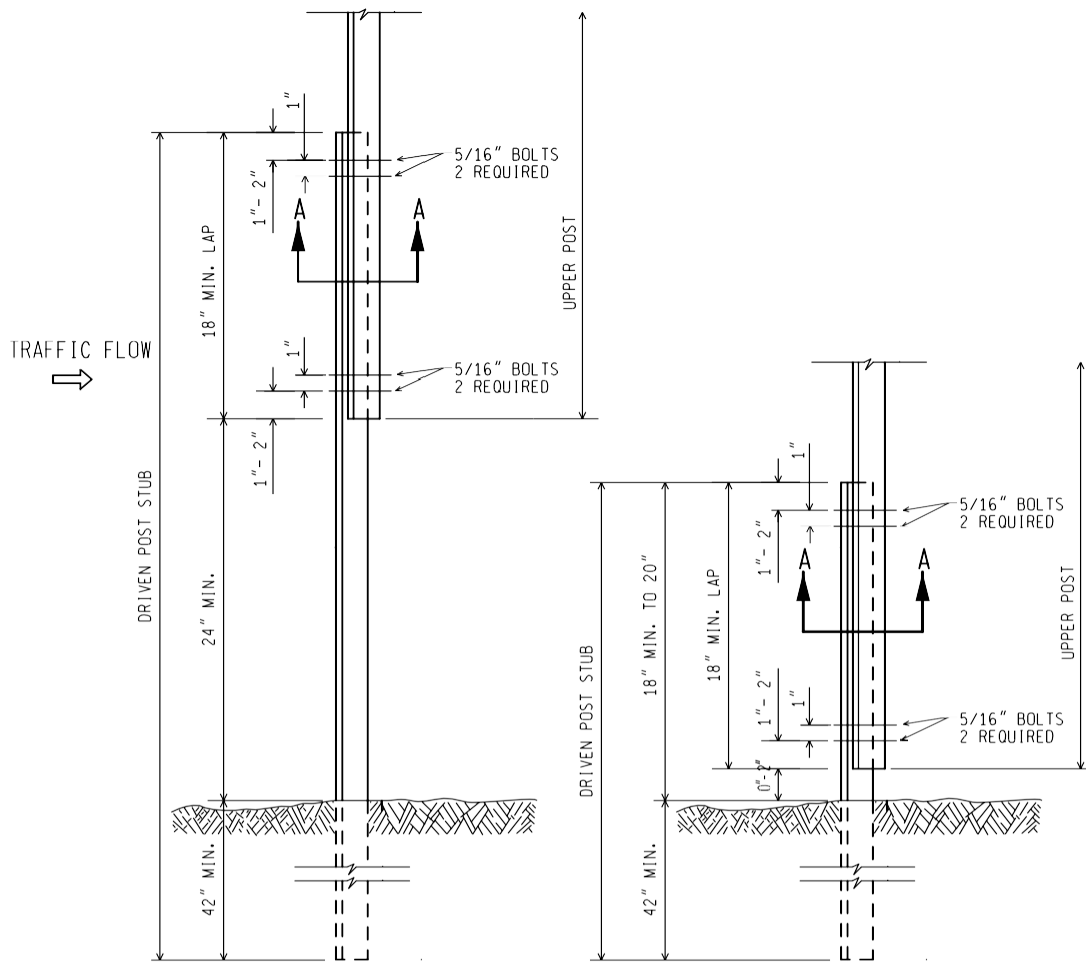

3 lb. U - CHANNEL STEEL POST
(WITH SPLICE)

MOUNT SIGN ON OPEN FACE OF
UPPER U - CHANNEL STEEL POST

NOT TO SCALE

MICHIGAN DEPARTMENT OF TRANSPORTATION
BUREAU OF DEVELOPMENT STANDARD PLAN

F.H.W.A. APPROVAL

11/2/2017
PLAN DATE

WZD-100-A

SHEET
5 OF 11

NOTE: THE ORIGINAL SIGNED COPY IS KEPT ON FILE AT THE MICHIGAN DEPARTMENT OF TRANSPORTATION.

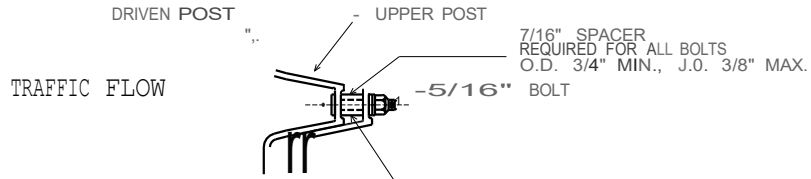

SECTION A-A

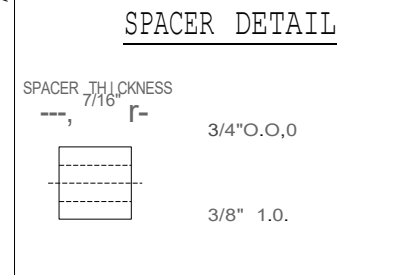

NOTES:

1. THE SPACER THICKNESS SHALL BE 1/16" LESS THAN THE GAP BETWEEN THE POST WHEN POSITIONED IN THE UNBOLTED CONFIGURATION.
2. THE EXTERIOR BOLT (CLOSEST TO LAP), SPACER, WASHER, AND NUT SHALL BE INSTALLED IN A PREPUNCHED HOLE 1" TO 2" FROM THE END OF THE LAP.
3. THE INTERIOR BOLT (FARTHEST FROM LAP), SPACER, WASHER, AND NUT SHALL BE INSTALLED IN THE NEXT PREPUNCHED HOLE.
4. THE DRIVEN POST SHALL ALWAYS BE MOUNTED IN FRONT OF THE UPPER POST WITH RESPECT TO THE ADJACENT ONCOMING TRAFFIC, REGARDLESS OF THE DIRECTION THE SIGN IS FACING.
5. THE SPLICE LAP SHALL BE FASTENED BY FOUR-5/16" DIA. GALVANIZED A449 BOLTS (SAE J429 GRADE 5) OR GALVANIZED A325 BOLTS.

3 lb. U - CHANNEL STEEL POST
(WITH SPLICE)

NOT TO SCALE

MICHIGAN DEPARTMENT OF TRANSPORTATION BUREAU OF DEVELOPMENT STANDARD PLAN	F.H.w.A. APPROVAL	<u>11/2/2017</u> PLAN DATE	WZD-100-A	SHEET 6 OF 11
--	-------------------	-------------------------------	-----------	------------------

NOTE: THE ORIGINAL SIGNED COPY IS KEPT ON FILE AT THE MICHIGAN DEPARTMENT OF TRANSPORTATION.

5/16" DIAMETER GALVANIZED BOLT AND NUT

SELF-ALIGNING STEEL REINFORCING PLATE (TYPE ALUMINUM SHEET [TYPE 111] SIGN ONLY)

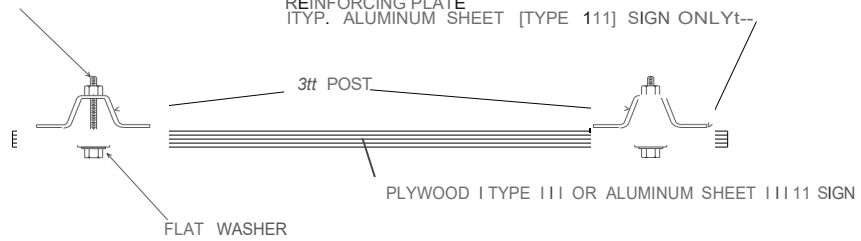

SIGN TO 3 lb. POST CONNECTION

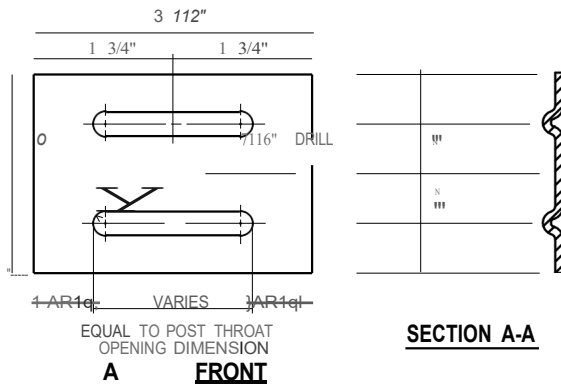

NOTES: (FOR STEEL SIGN REINF' PLATE)

1. MATERIAL: 12 GAUGE CARBON STEEL.
2. TOLERANCE ON ALL DIMENSIONS ±0.0625"
3. FINISH-AFTER STAMPING AND PUNCHING, GALVANIZE ACCORDING TO CURRENT SPECIFICATIONS FOR ZINC (HOT GALVANIZE) COATINGS ON PRODUCTS FABRICATED FROM PLATES OR STRIPS

STEEL SIGN REINFORCING PLATE
REQUIRED FOR TYPE III SIGNS ONLY

3 lb. U - CHANNEL STEEL POST SIGN CONNECTION

NOT TO SCALE

MICHIGAN DEPARTMENT OF TRANSPORTATION
BUREAU OF DEVELOPMENT STANDARD PLAN

F.H.W.A. APPROVAL

11/2/2017
PLAN DATE

WZD-100-A

SHEET
7 OF 11

NOTE: THE ORIGINAL SIGNED COPY IS KEPT ON FILE AT THE MICHIGAN DEPARTMENT OF TRANSPORTATION.

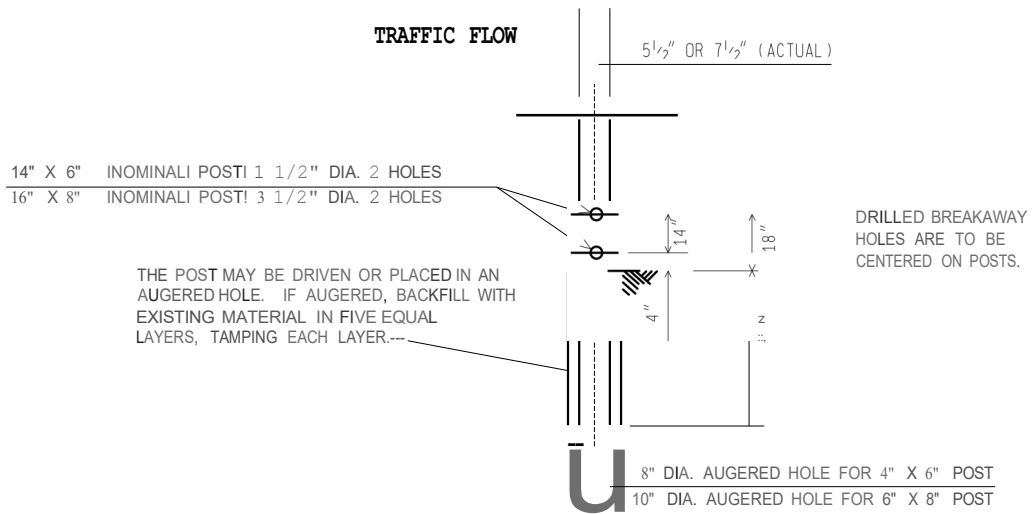

**WOOD POST BREAKAWAY HOLES/
DIRECT EMBEDMENT DETAILS**

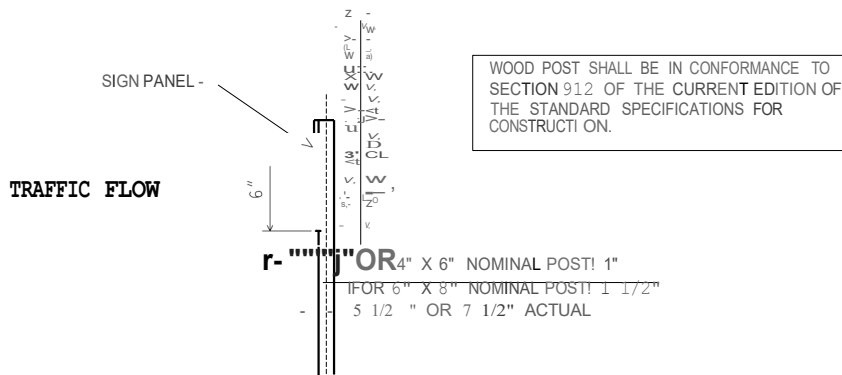

**SAW CUT DETAIL
(MULTIPLE POST INSTALLATIONS)**

WOOD POST DETAILS

NOT TO SCALE

MICHIGAN DEPARTMENT OF TRANSPORTATION BUREAU OF DEVELOPMENT STANDARD PLAN	f.H.w.A. APPROVAL	11/2/2017 PLAN DATE	WZD-100-A	SHEET 8 OF 11
--	-------------------	------------------------	-----------	------------------

NOTE: THE ORIGINAL SIGNED COPY IS KEPT ON FILE AT THE MICHIGAN DEPARTMENT OF TRANSPORTATION.

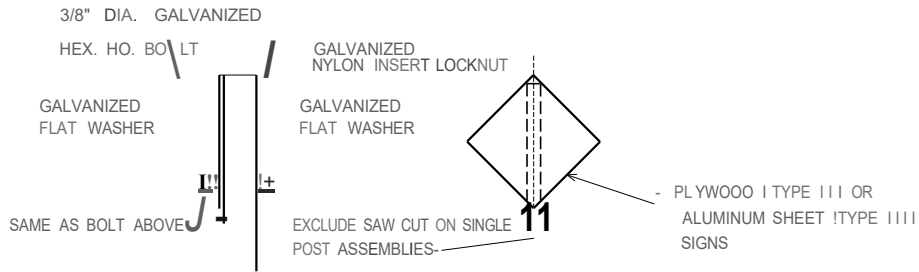

TYPE II AND TYPE III SIGNS

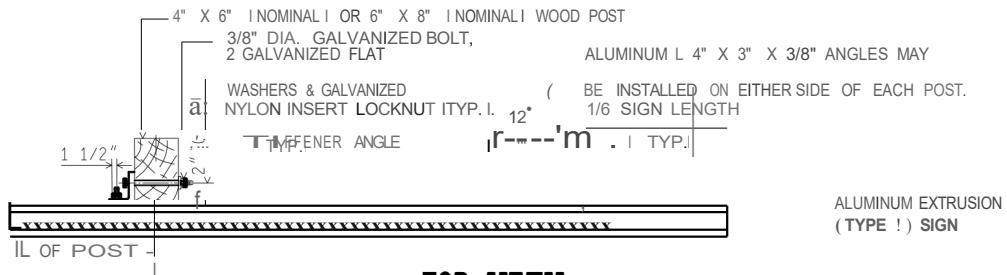

**TOP VIEW
TYPE I SIGN**

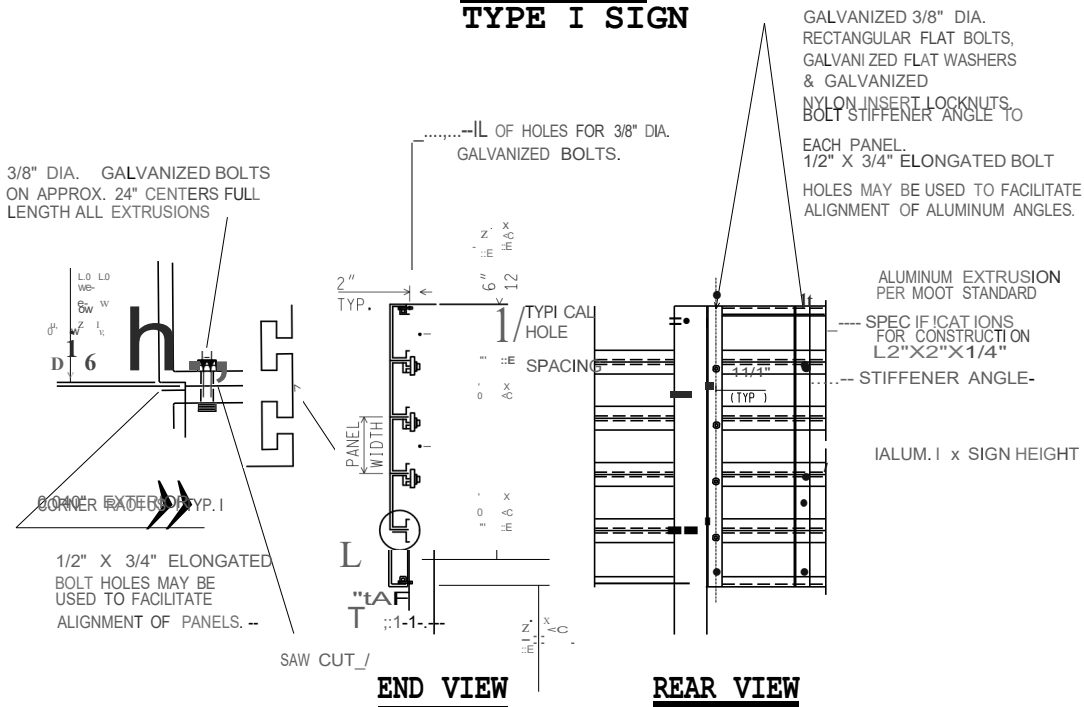

TYPE I SIGN - ERECTION DETAILS

WOOD POST CONNECTIONS

NOT TO SCALE

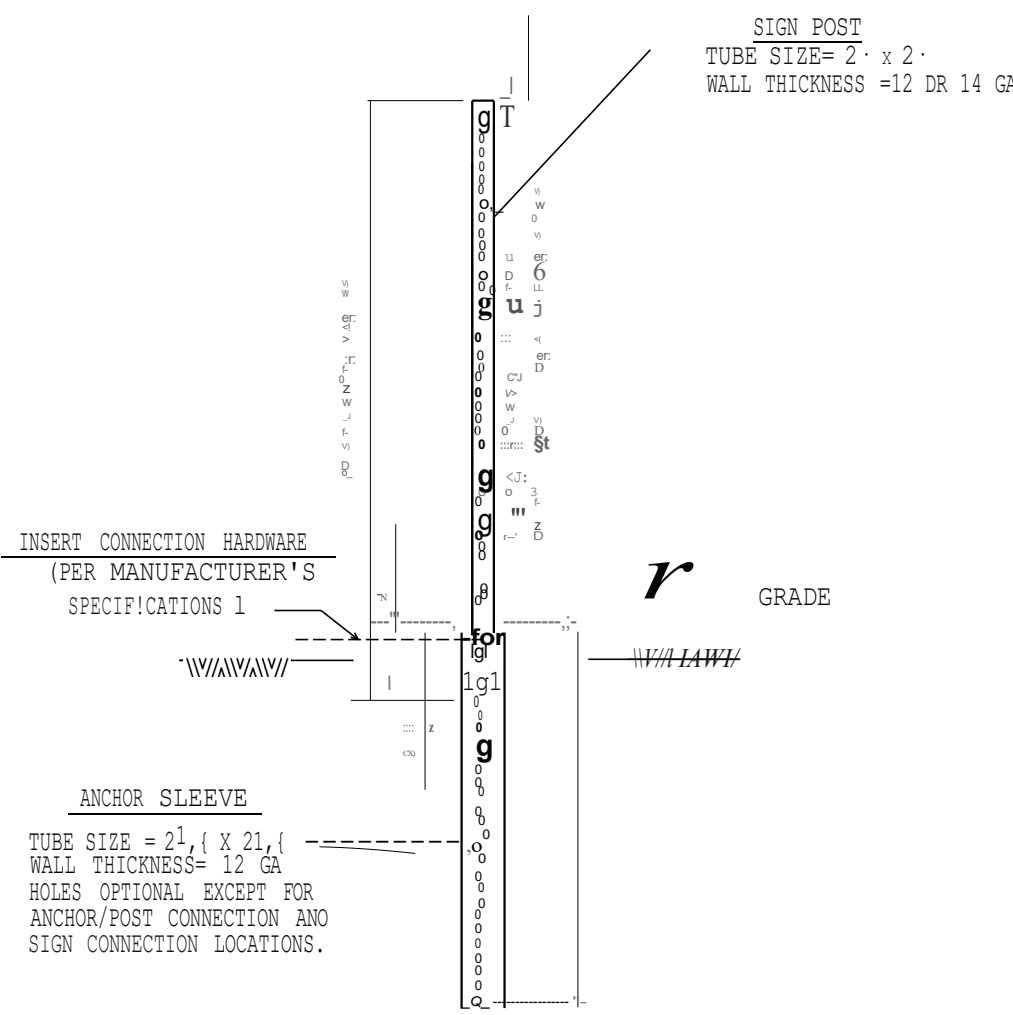

SQUARE TUBULAR STEEL POST

NOT TO SCALE

<p>MICHIGAN DEPARTMENT OF TRANSPORTATION BUREAU OF DEVELOPMENT STANDARD PLAN</p>	<p>F.H.w.A. APPROVAL</p>	<p>11/2/2017 PLAN DATE</p>	<p>WZD-100-A</p>	<p>SHEET 10 OF 11</p>
--	--------------------------	--------------------------------	------------------	---------------------------

NOTE: THE ORIGINAL SIGNED COPY IS KEPT ON FILE AT THE MICHIGAN DEPARTMENT OF TRANSPORTATION.

GENERAL NOTES:

1. A MAXIMUM OF TWO POSTS WITHIN A 7 FOOT PATH IS PERMITTED.
2. ALL SIGN POSTS SHALL COMPLY WITH NCHRP 350.
3. ALL POSTS SHALL BE EMBEDDED A MINIMUM OF 42".
4. BRACING OF POST IS NOT PERMITTED.
5. SIGN SHALL BE LEVEL, AND UPRIGHT FOR THE DURATION OF INSTALLATION.
6. ERECT POSTS SO THE SIGN FACE AND SUPPORTS DO NOT VARY FROM PLUMB BY MORE THAN 3/16" IN 3'. PROVIDE A CENTER-TO-CENTER DISTANCE BETWEEN POSTS WITHIN 2 PERCENT OF PLAN DISTANCE.
7. NO MORE THAN ONE SPLICE PER POST, AS SHOWN, WILL BE PERMITTED.
8. POST TYPES SHALL NOT BE MIXED WITHIN A SIGN SUPPORT INSTALLATION.
9. NO VERTICAL JOINTS ARE PERMITTED IN SIGN. NO HORIZONTAL JOINTS THROUGH SIGN LEGEND OR SYMBOLS ARE PERMITTED IN SIGN
10. REMOVE SIGN POSTS AND/OR POST STUBS IN THEIR ENTIRETY WHEN NO LONGER REQUIRED.
11. ALL LABOR, MATERIALS, AND EQUIPMENT, INCLUDING TEMPORARY SUPPORTS REQUIRED TO INSTALL, MAINTAIN, RELOCATE, AND/OR REMOVE THE TEMPORARY SIGN, INCLUDING SUPPORTS, ARE CONSIDERED TO BE INCLUDED IN THE COST OF THE TEMPORARY SIGN.
12. SAW CUTS IN WOOD POSTS ARE TO BE PARALLEL TO THE BOTTOM OF THE SIGN.
13. POSTS SHALL NOT EXTEND MORE THAN 4" ABOVE TOP OF SIGN.
14. TEMPORARY WOOD SUPPORTS DO NOT REQUIRE PRESERVATIVE TREATMENT.

NOT TO SCALE

MICHIGAN DEPARTMENT OF TRANSPORTATION BUREAU OF DEVELOPMENT STANDARD PLAN	F.H.w.A. APPROVAL	11/2/2017 PLAN DATE	WZD-100-A	SHEET 11 of 11
--	-------------------	------------------------	-----------	-------------------

NOTE: THE ORIGINAL SIGNED COPY IS KEPT ON FILE AT THE MICHIGAN DEPARTMENT OF TRANSPORTATION.

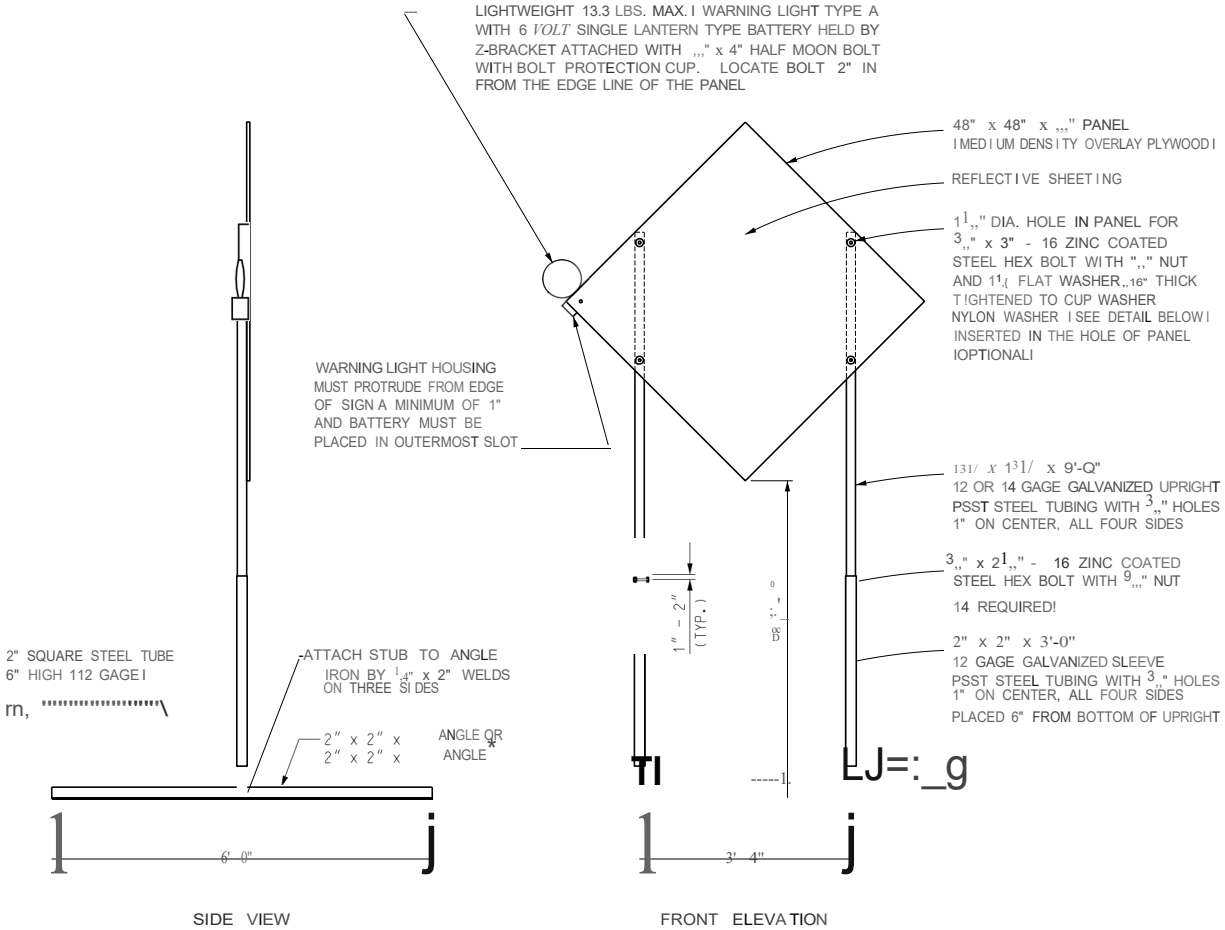

TEMPORARY SIGN SUPPORT

!WARNING LIGHT PLACED ON SIDE CLOSEST TO TRAFFIC!

* SIGN STAND IS BALLASTED WITH FOUR OR MORE 35 LB SANDBAGS. A MINIMUM OF ONE ON EACH END. UPRIGHTS SHALL NOT EXTEND ABOVE THE SIGN PANEL.

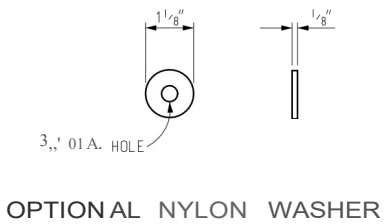
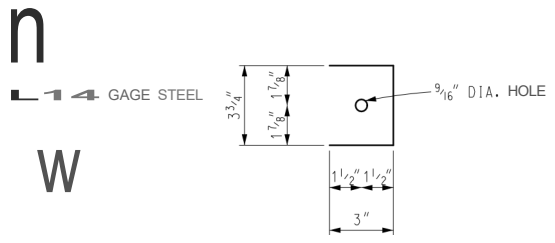

Other temporary sign supports meeting current NCHRP crash worthy criteria can be found on the FHWA Safely website at http://safely.fhwa.dol.gov/roadway_depl/road_hardware/wzd.html

NOT TO SCALE

MICHIGAN DEPARTMENT OF TRANSPORTATION BUREAU OF FIELD SERVICES SPECIAL DETAIL	SPECIAL DETAIL F.H.W.A. APPROVAL	6/16/22 PLAN DATE	WZD-125-E	SHEET 2 OF 3
--	-------------------------------------	----------------------	------------------	-----------------

NOTE: THE ORIGINAL SIGNED COPY IS KEPT ON FILE AT THE MICHIGAN DEPARTMENT OF TRANSPORTATION.

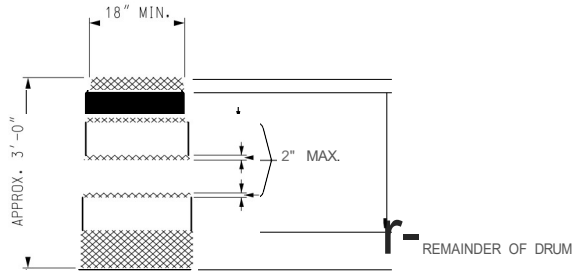

- REFLECTORIZED ORANGE
- C=::J REFLECTORIZED WHITE
- NON REFLECTORIZED ORANGE

NOTE:
 DRUMS SHALL HAVE AT LEAST 4 HORIZONTAL REFLECTORIZED STRIPES 12 ORANGE AND 2 WHITE 1 OF 6" UNIFORM WIDTH, ALTERNATING IN COLOR WITH THE TOPMOST REFLECTORIZED STRIPE BEING ORANGE. NON REFLECTORIZED SPACES BETWEEN THE HORIZONTAL REFLECTORIZED ORANGE AND WHITE STRIPES SHALL BE ORANGE IN COLOR AND EQUAL IN WIDTH.

PLASTIC DRUM

NOTES:

2" PERFORATED SQUARE STEEL TUBES MAY BE USED TO FABRICATE THE HORIZONTAL BASE OF THE TYPE 111 BARRICADE.

WARNING LIGHTS SHALL BE PLACED ACCORDING TO THE CURRENT STANDARD SPECIFICATIONS FOR CONSTRUCTION AND ALL OTHER PROVISIONS IN THE CONTRACT ON TYPE 111 BARRICADES.

SEE ROAD STANDARD PLANS R-113-SERIES FOR TEMPORARY CROSOVERS FOR DIVIDED ROADWAY, AND R-126-SERIES FOR TYPICAL LOCATION AND SPACING OF PLASTIC DRUMS FOR PLACEMENT OF TEMORARY CONCRETE BARRIER.

SIGNS, BARRICADES, AND PLASTIC DRUMS SHALL BE FACED WITH PRESSURE-SENSITIVE REFLECTIVE SHEETING ACCORDING TO THE CURRENT STANDARD SPECIFICATIONS FOR CONSTRUCTION.

SANDBAGS SHALL BE USED WHEN SUPPLEMENTAL WEIGHTS ARE REQUIRED TO ACHIEVE STABILITY OF THE BARRICADE. THE SANDBAGS SHALL BE PLACED SO THEY WILL NOT COVER OR OBSTRUCT ANY REFLECTIVE PORTION OF THE TRAFFIC CONTROL DEVICE.

NOT TO SCALE

MICHIGAN
DEPARTMENT OF TRANSPORTATION

SPECIAL PROVISION
FOR
VERTICAL EXPLORATORY INVESTIGATION FOR RELOCATION

COS:MRB

1 of 2

APPR:DMG:NAL:04-30-20
FHWA:APPR:05-06-20

a. Description. When proposed work must be relocated as directed by the Engineer, this special provision is used to compensate the Contractor to locate and expose underground infrastructure and obstructions, such as culverts, sewers and utilities. Perform this work only when conflicts are found in the planned work location. This special provision is not to compensate for the Contractor’s responsibilities in subsection 107.12 of the Standard Specifications for Construction.

b. Materials. Use Granular Material Class III in accordance with section 902 of the Standard Specifications for Construction for backfill. Use material removed during exploratory investigation for backfill only if approved by the Engineer.

c. Construction. The owner of any sewer or utility to be exposed will not take the facilities out of service during the exploratory investigation. Contact utility owners in accordance with subsection 107.12 of the Standard Specifications for Construction.

Advance the exploratory excavation using vacuum excavation, hand digging, conventional machine excavation, or a combination thereof subject to approval of the Engineer. Allow the Engineer access to document the necessary information. If the technique used to advance the excavation causes any damage to the existing facilities, immediately contact the utility owner and cease all work until an alternate method is approved by the Engineer.

Take care to protect the exposed culvert, sewer or utility from damage during construction. The Contractor is responsible for all costs associated with the repair work and out of service time of all broken or damaged existing culverts, sewers or utilities as a result of any action by the Contractor. If the exploratory investigation results in damage to utilities, contact the owner of such utility to coordinate the repair. Repair or replace culvert, sewer or utility, damaged during exploratory excavation, in accordance with the standard specifications and as approved by the Engineer.

Obtain the Engineer's approval before backfilling the excavation. Complete backfilling no later than 24 hours after approval has been given. Backfill in accordance with subsection 204.03.C of the Standard Specifications for Construction. Dispose of excess material in accordance with the standard specifications.

d. Measurement and Payment. The completed work, as described, will be measured and paid for at the contract unit price using the following pay item:

Pay Item	Pay Unit
Exploratory Investigation, Vertical	Foot

Exploratory Investigation, Vertical will be measured by the foot from top of existing grade vertically to the bottom of the excavation for up to a 4-foot maximum diameter hole, or as approved by the Engineer. The excavated depth of each 4-foot maximum diameter hole will be measured separately for payment.

Exploratory Investigation, Vertical includes all costs associated with repair or replacement resulting from the Contractor's activities. Providing necessary lane, shoulder and/or sidewalk closures required to perform work will be paid for by other associated items in the contract. Restoration work will be paid for by other associated items.